

# Operating Manual

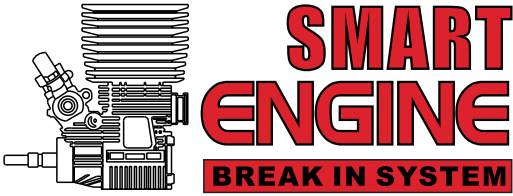



## IMPORTANT SAFTY INSTRUCTION

**BEFORE USING THIS MACHINE READ ALL INSTRUCTIONS AND CAUTIONS MARKINGS IN THE MANUAL AND ON THE MACHINE**

When using a Machine, basic precautions should always be followed, include the following:

## WARNING

**These warnings apply to the machine, and also where applicable, to all tools, accessories, power supply unit or main adaptors.**

**TO REDUCE THE RISK OF FIRE, ELECTRIC SHOCK, OR INJURY:**







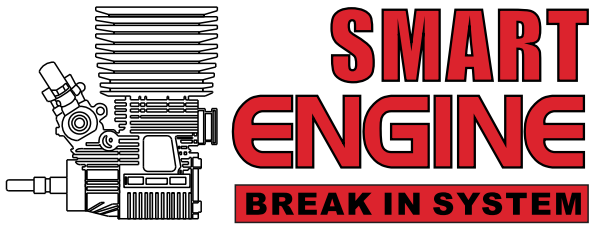





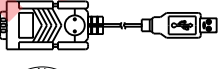
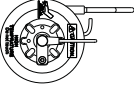

1. This machine is not intended for use by persons (including children) with reduced physical, sensory or reasoning capabilities, or lack of experience and knowledge, unless they have been given supervision or instruction concerning use of machine by a person responsible for their safety.
2. Do not allow to be used as a toy. Close attention in necessary when used by or near children should be supervised to ensure that they do not play with machine.
3. Use only described in this Operation Manual. Do not carry out any maintenance other than that shown in this manual, or advised by the distributors.
4. Suitable for outdoors dry locations ONLY. Do not use indoors or on wet surfaces
5. Do not handle any part of the plug or machine with wet hands.
6. Do not use with a damaged cord or plug. If the supply cord is damaged it must be replaced in order to avoid hazard.
7. If the machine is not working as it should, has been dropped, damaged or drenched by liquid, do not use and contact distributors.
8. Contact the distributors when service or repair is required. Do not disassemble the machine as incorrect reassembly may result in an electric shock or fire.
9. Do not stretch the cord or place the cord under strain. Keep the cord away from heated surface. Do not pull the cord around sharp edges or corners. Arrange the cord away from traffic areas and where it will not stepped on or tripped over. Do not run the machine over the cord.
10. Do not unplug by pulling on the cord. To unplug, grasp the plug, not the cord.
11. Do not put any object into openings. Do not use with any opening blocked: anything that may reduce airflow.
12. Use only recommended accessories and replacement parts.
13. Unplug from power supplies when not in use for extended periods and before maintenance or servicing.
14. Use only recommended power supply unit and battery for operating this machine: other types of power supply unit and batteries may burst, causing injury to persons and damage.

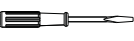
## READ AND SAVE THESE INSTRUCTIONS

THIS MACHINE IS INTENDED FOR PRESONAL USE ONLY NOT FOR COMMERCIAL USE

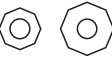

## Accessory and spare part list:

- |   |   |
|---|---|
| 1. CD x1 -----  |    |
| 2. Fuel tank x1 -----   |    |
| 3. Rs232 Cable x1 -----   |    |
| 4. Heating Element with Temp. Sensor x1 -----                   |    |
| 5. Fuel Tank Stand x2 -----                                     |   |
| 6. Exhaust Adaptor OS Type x1 -----<br>(Already fix on machine) |  |
| 7. Exhaust Adaptor Picco Type x1 -----                          |  |
| 8. Fly wheel x1 -----   |  |
| 9. Screw Driver (For Turning engine idling) x1 -----            |  |
| 10. Wrench (For RPM Sensor adjustment) x1 -----                 |  |
| 11. Operating Manual x1 -----                                   |  |
| 12. Service Manual x1 -----                                     |  |
| 13. Friction Washer x2 -----<br>(Spare Part)                    |  |
| 14. Fuse 40A x1 15A x1 3A x1 -----<br>(Spare Part)              |  |
| 15. Aluminum box x1 -----                                       |  |
| 16. Engine screw shim x1 -----                                  |  |
| 17. Fuse clip x1 -----  |  |



# Specification

Software Version 25.1

Mode	Temperature	Engine RPM	Operating Cycle/Throttle curve
Mode1	90°/Engine Star	Operating 8000±500RPM 12000 RPM Break System on	Cycle: 1/4 ~ 4/4
	95°/Cooling Fan on		Operating Cycle Time 15 Min.
	88°/Heater On		Cooling Period 3 Min. once engine reach 40°
	105°/Break System On		Throttle @ 1 Min. /+30PWM
Mode2	90°/Engine Star	Operating 9000±500RPM 13000 RPM Break System on	Cycle: 1/4 ~ 4/4
	95°/Cooling Fan on		Operating Cycle Time 15 Min.
	88°/Heater On		Cooling Period 3 Min. once engine reach 40°
	105°/Break System On		Throttle @ 1 Min. /+30PWM
Mode3 (Default value)	90°/Engine Star	Operating 8000±500RPM 20000 RPM Break System on	Cycle: 1/4 ~ 4/4
	95°/Cooling Fan on		Operating Cycle Time 15 Min.
	88°/Heater On		Cooling Period 3 Min. once engine reach 40°
	120°/Break System On		
Mode4 (Default value)	90°/Engine Star	Operating 8000±500RPM 20000 RPM Break System on	Cycle: 1/4 ~ 4/4
	95°/Cooling Fan on		Operating Cycle Time 15 Min.
	88°/Heater On		Cooling Period 3 Min. once engine reach 40°
	125°/Break System On		

Error Code	Definition
01	RPM lower then the operating setting
02	It was not successful to star more then three times
03	The heating temperature has not reached the specified temperature for more then 20 minutes
04	Completed the cycle
05	Engine is not adjusted to the specified request, stop operation by break system
06	Engine temperature is exceed the specified value
07	Engine speed is exceed the specified value
08	Engine stopped cause by fuel is not enough
09	Fly wheel can't return to proper position

# Fuel tank installation:

Step 1: Fix fuel tank with mounting plate.

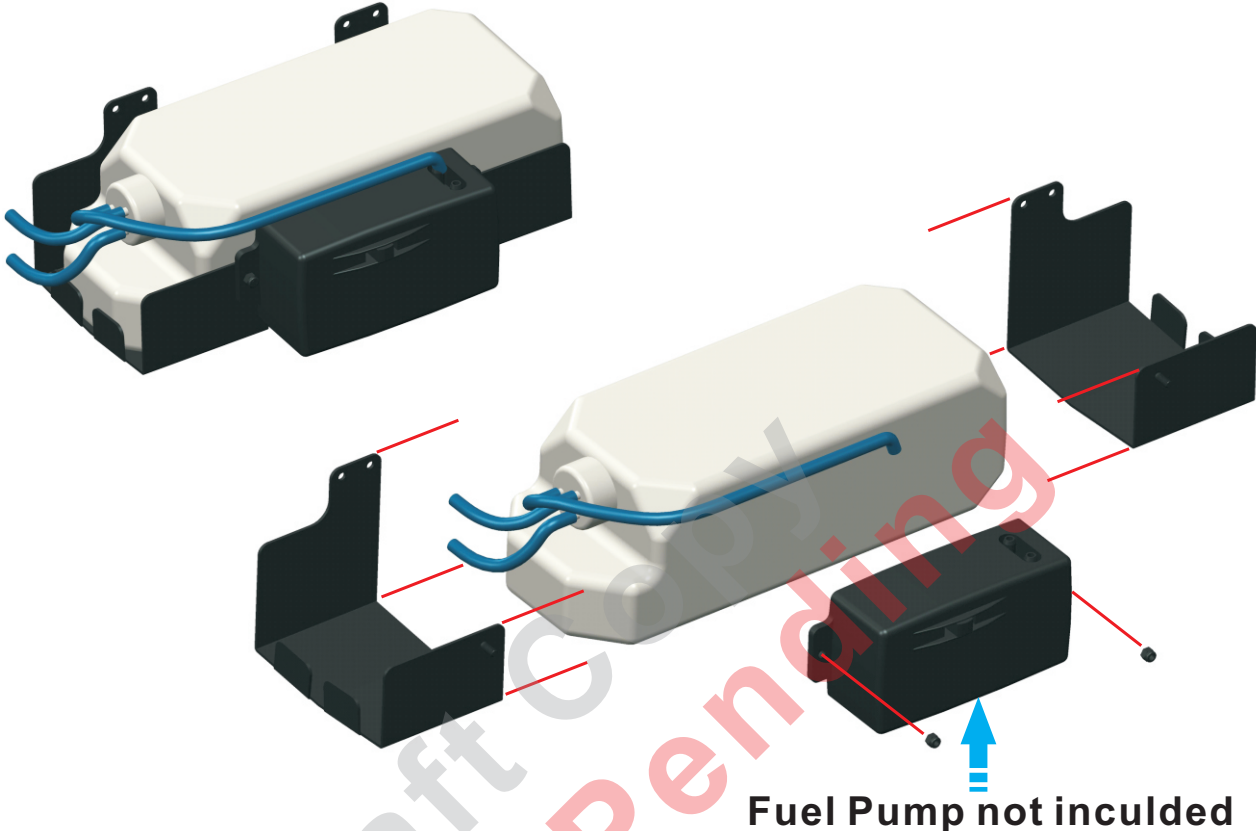

Step 2: Install fuel tank on the machine

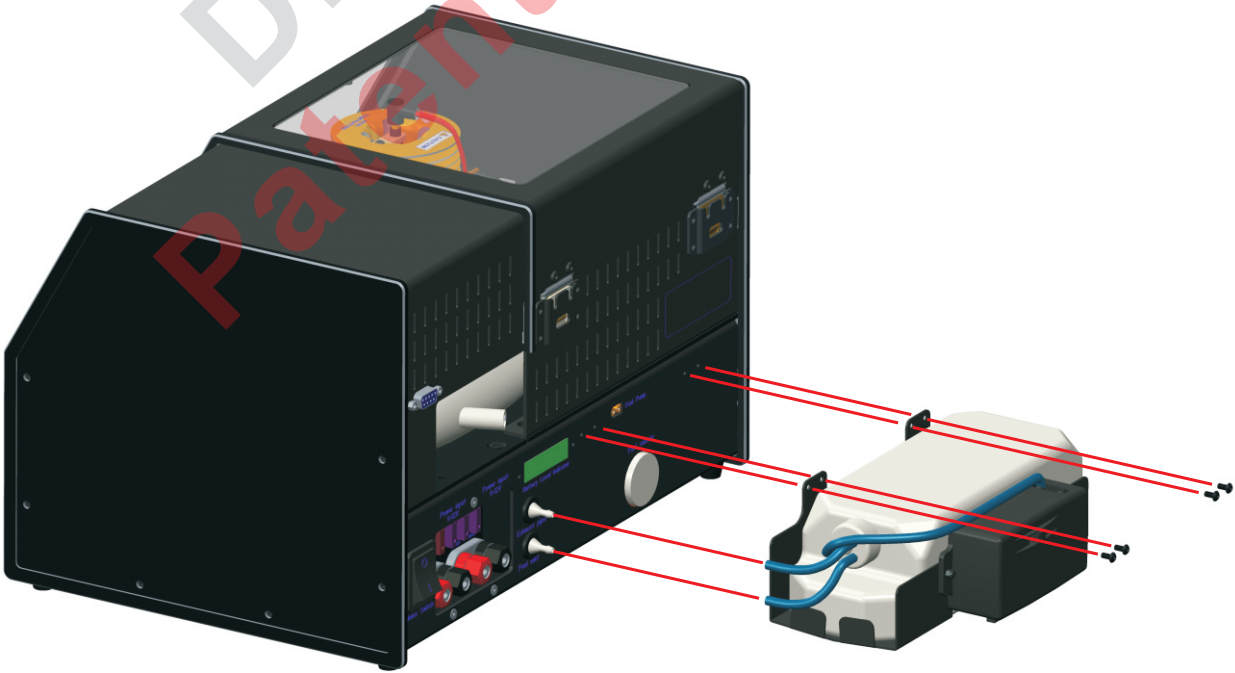

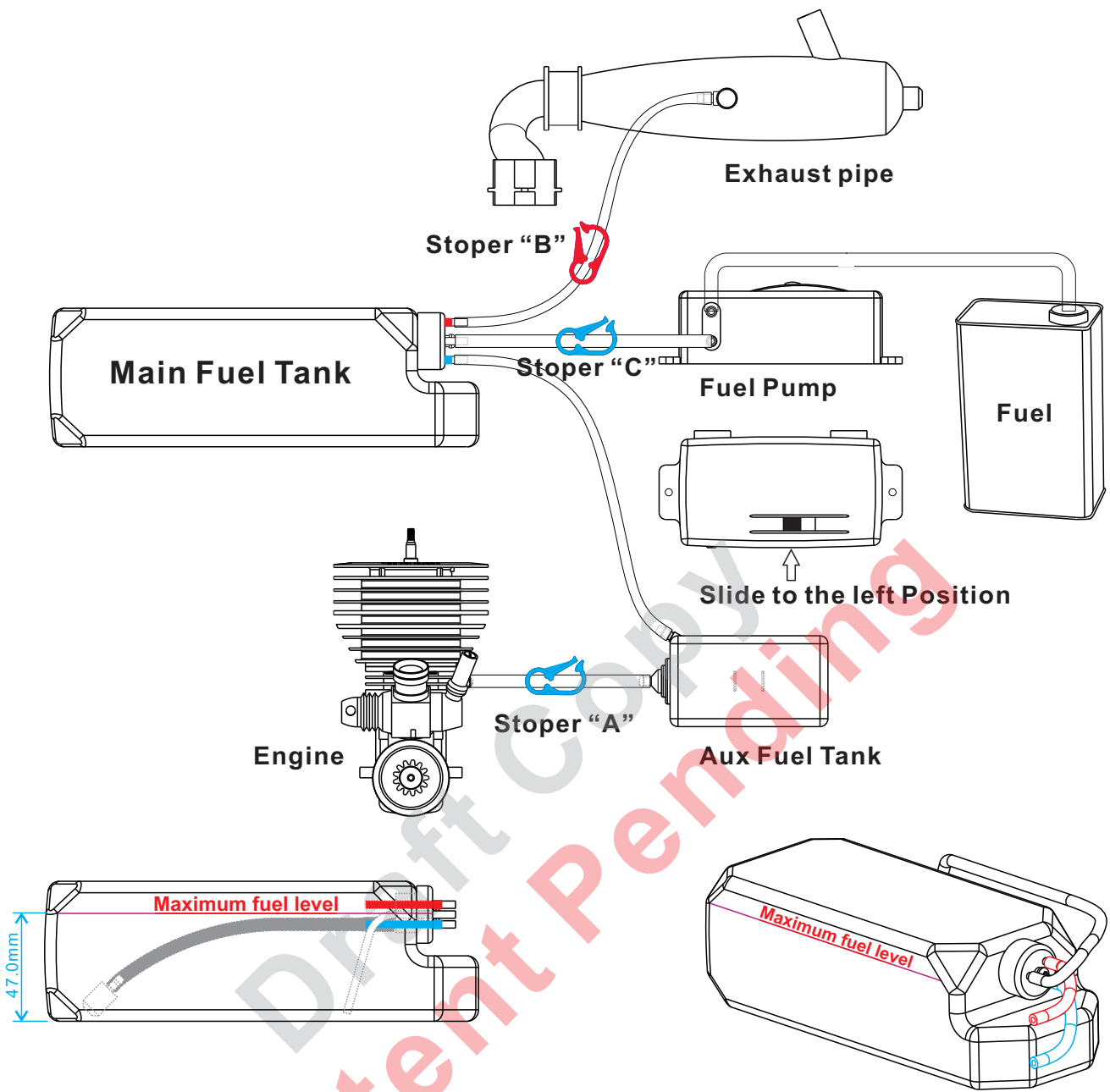

Remark : When normal Operation, stoper "A" , "B" is open and "C" is close.

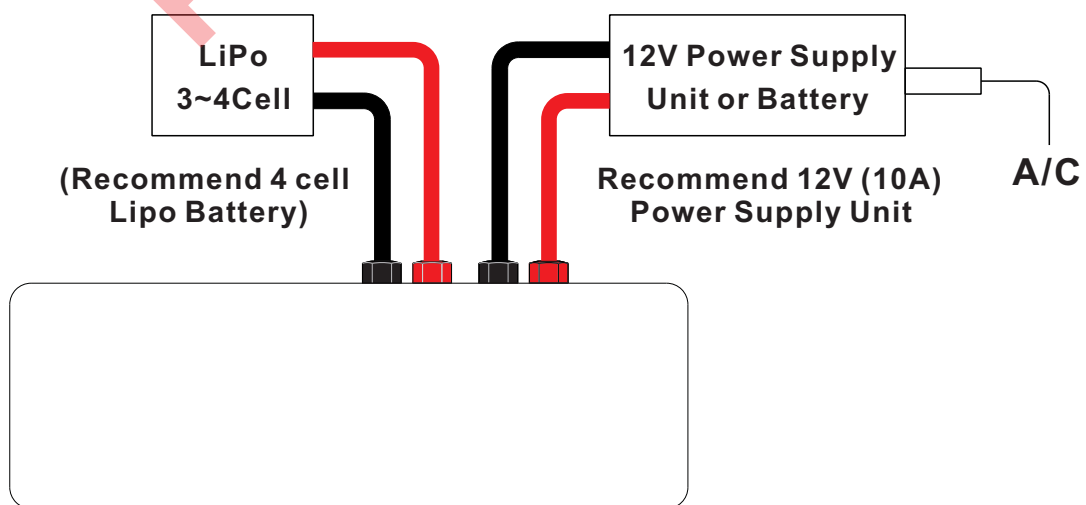

# Keyboard description

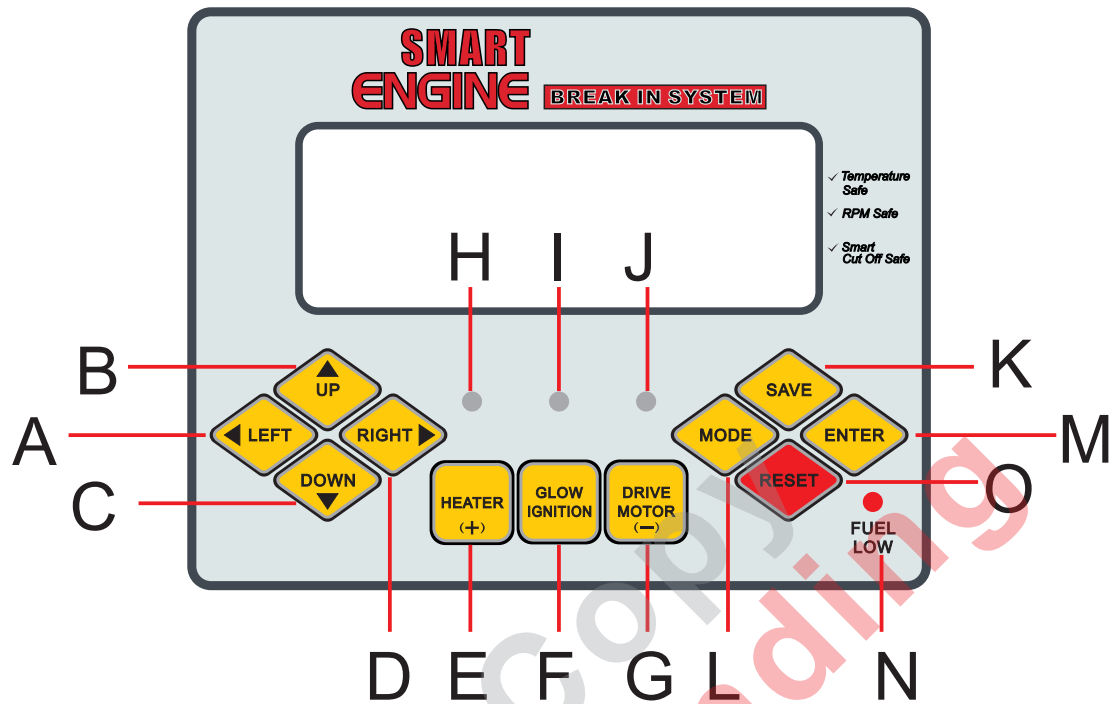

- A Left key
- B Up key
- C Down key
- D Right key
- E Heater ON/OFF(Manual mode use only)
- F Ignition ON/OFF(Manual mode use only)
- G Starter motor ON/OFF(Manual mode use only)
- H Heater indicator
- I Ignition indicator
- J Starter indicator
- K Save key (Manual mode Cooling fan ON/OFF)
- L Mode key
- M Enter key
- N Fuel lower indicator
- O Reset key

# Equipment guidelines

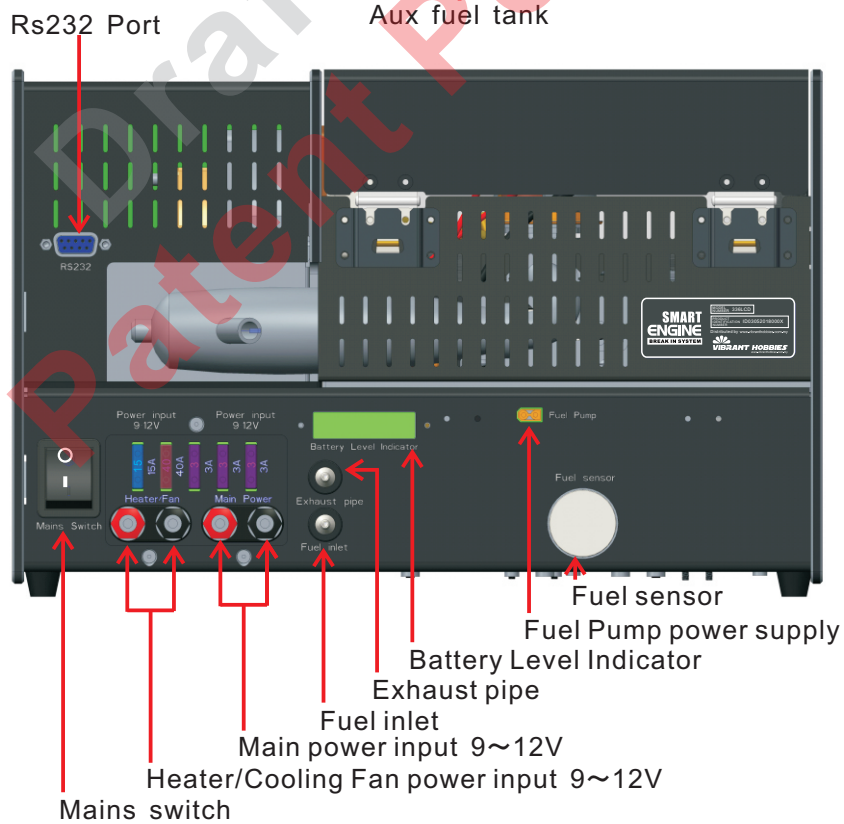
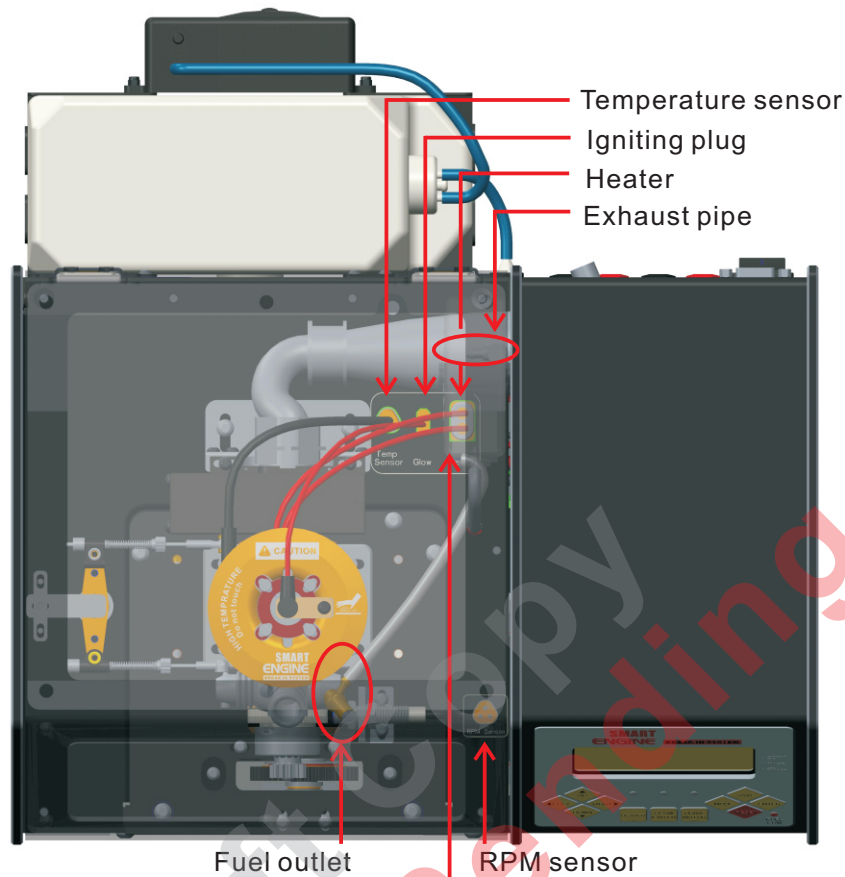

- A、Heater Unit Fuse(15A)
- B、Starter Motor Fuse(40A)
- C、Igniting Fuse(3A)
- D、Fuel pumb Fuse(3A)
- E、CPU Board Fuse(3A)

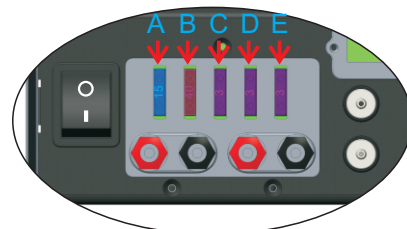



# 1、 Engine installation guide

Use the original screw removed from the engine

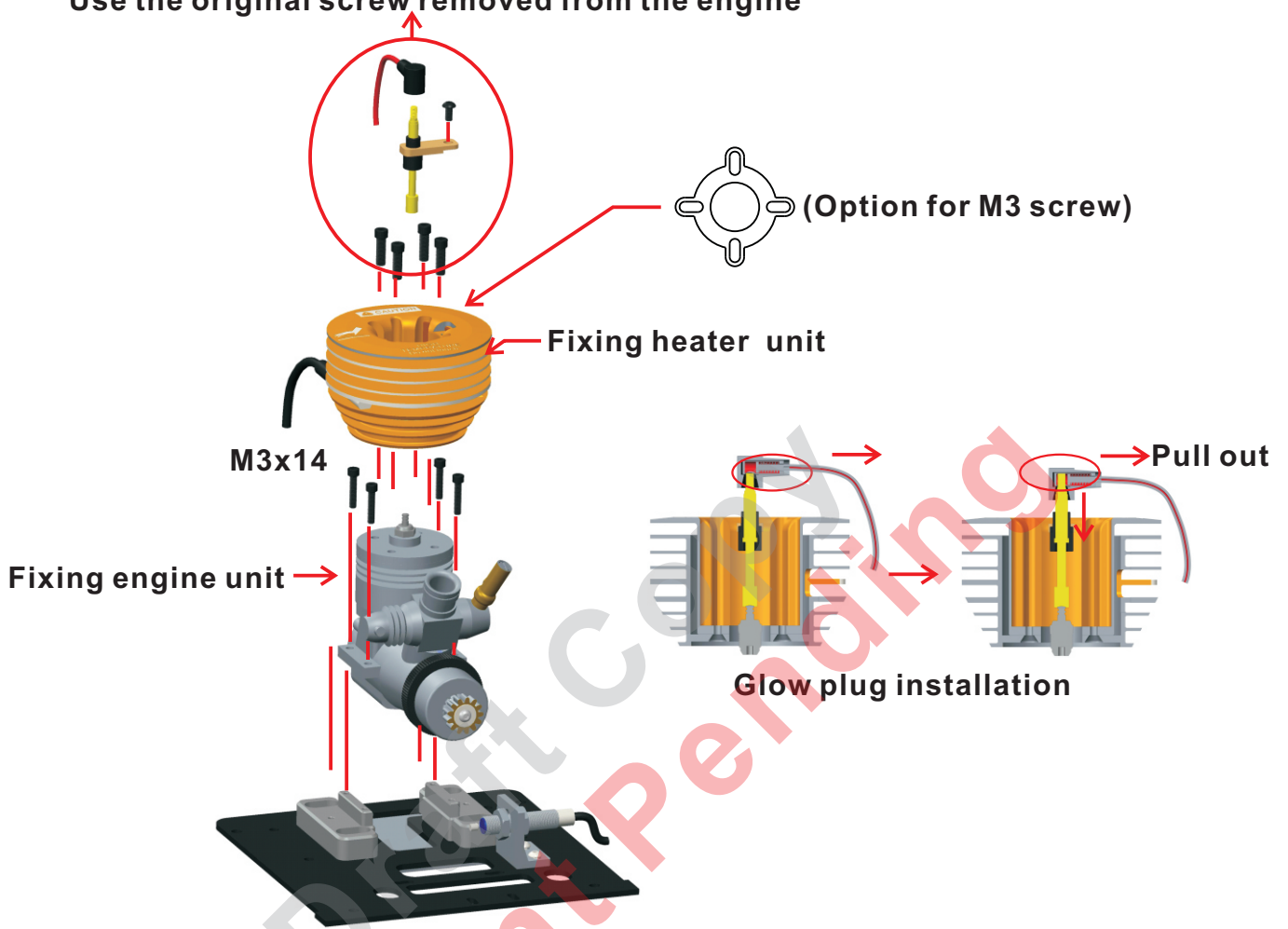

Before installing the flywheel, the engine crankshaft must be turned clockwise Near TDC. (Note there must be no overcrowding between piston and cylinder liner)

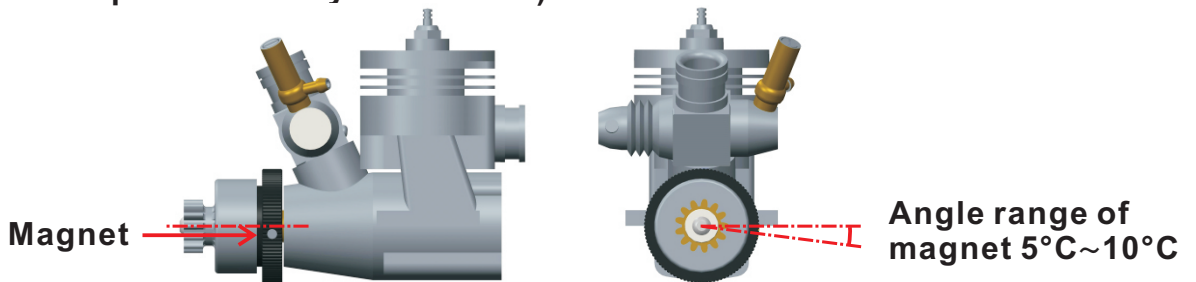

When installing the flywheel, the magnet on the flywheel must be in the horizontal position on the right.

## 2. Break system and engine mount adjustment guidelines

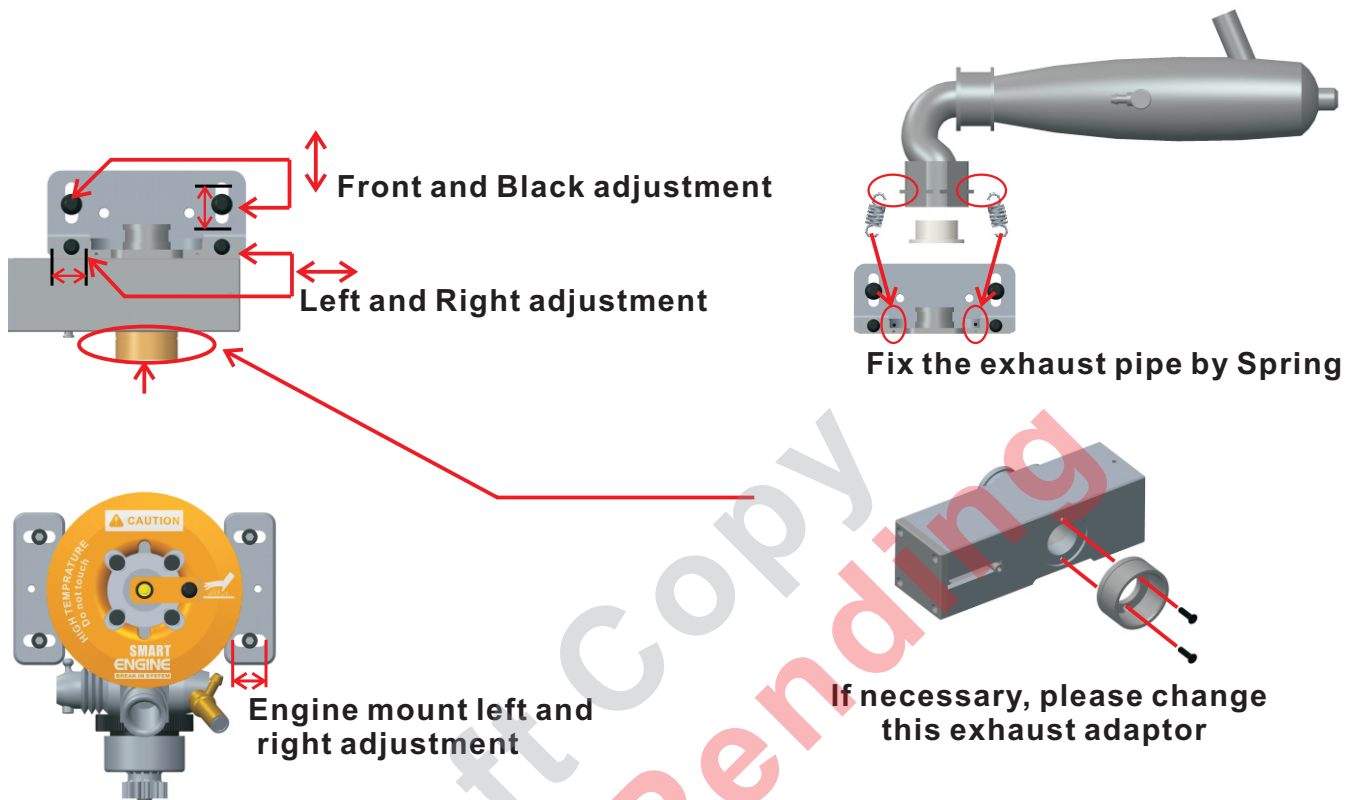

## 3. RPM sensor adjustment guidelines

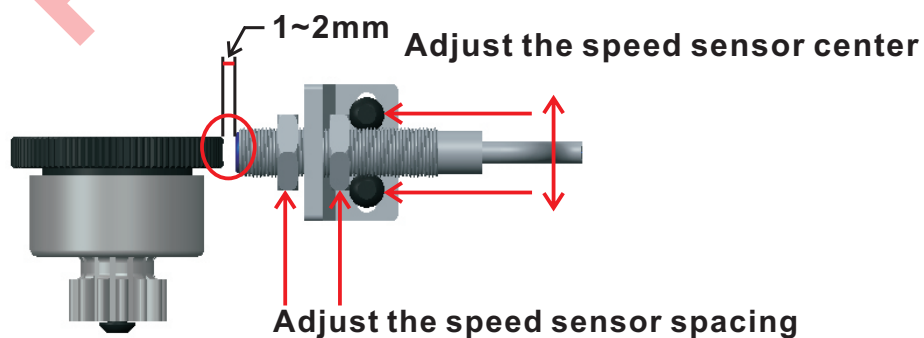

## 4. Throttle and break traveling adjustment guidelines

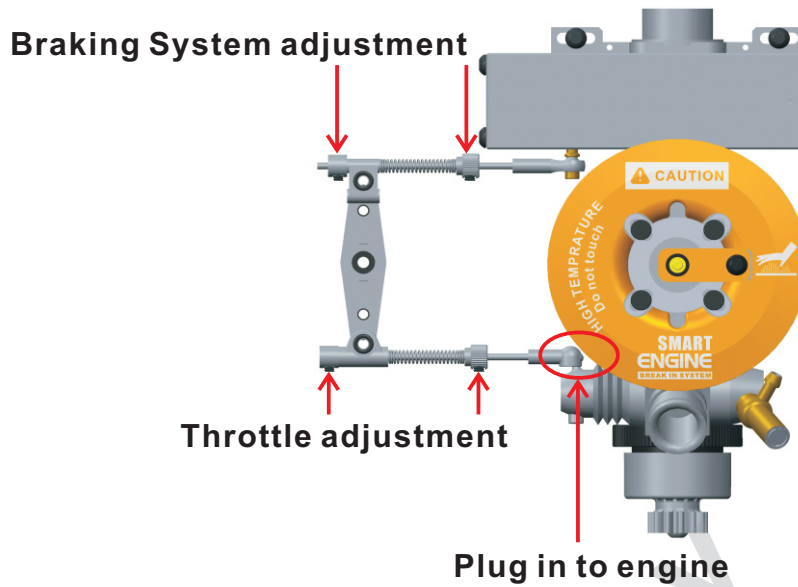

## 5. Starter rubber position adjustment

- 1) . Loose the set screw (Left and right) above 5 turns before adjust.
- 2) . Turn the alignment screw to adjust starter rubber to match the flywheel.
- 3) . Fix the set screw (Left and Right) once the position confirmed.

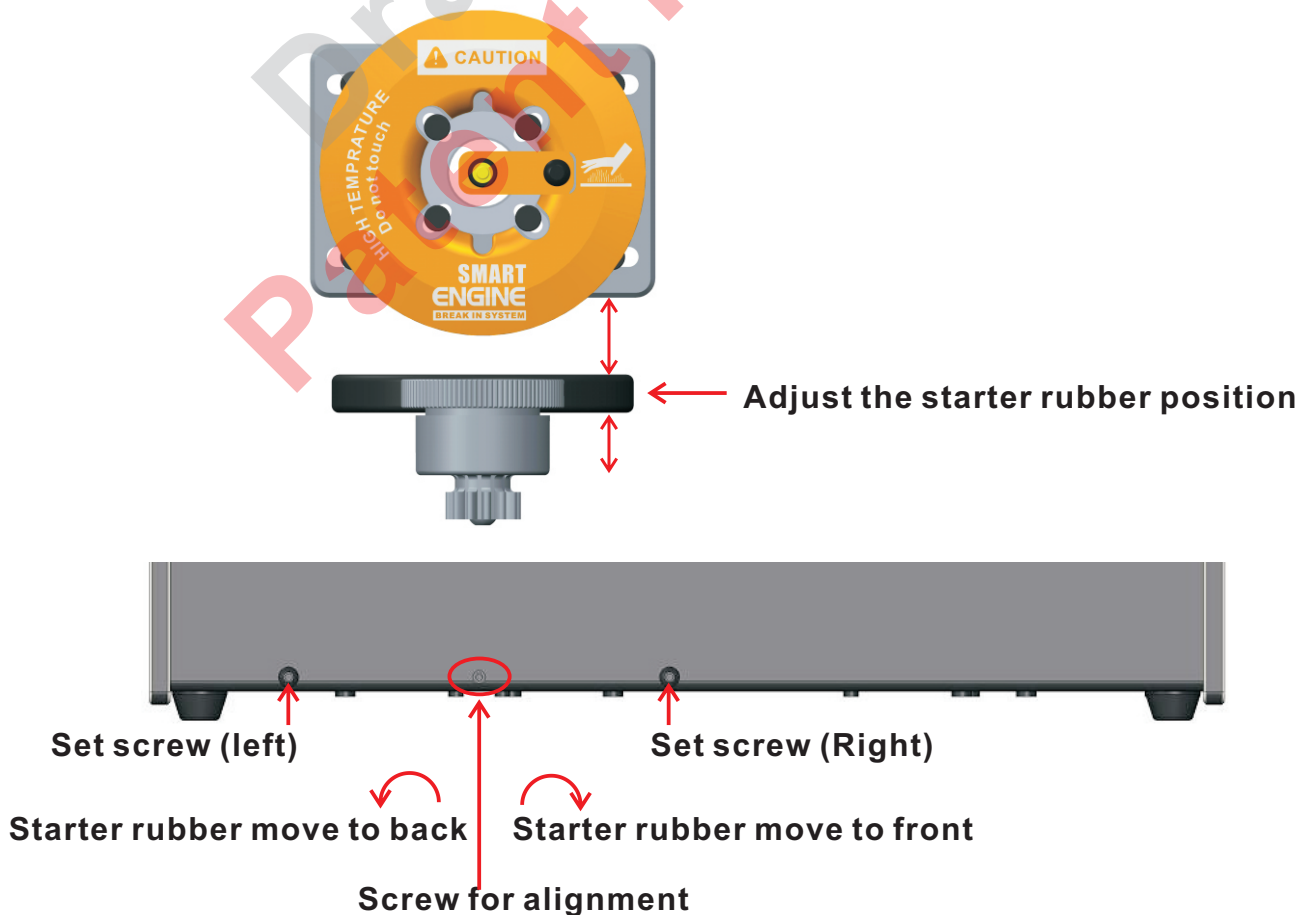

# 6. Loading installation guide

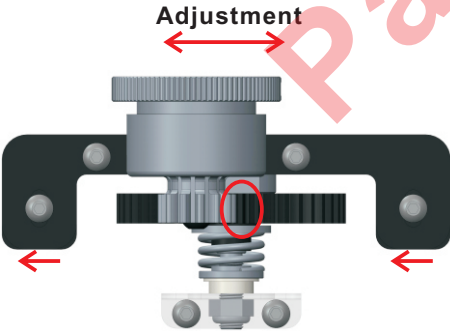
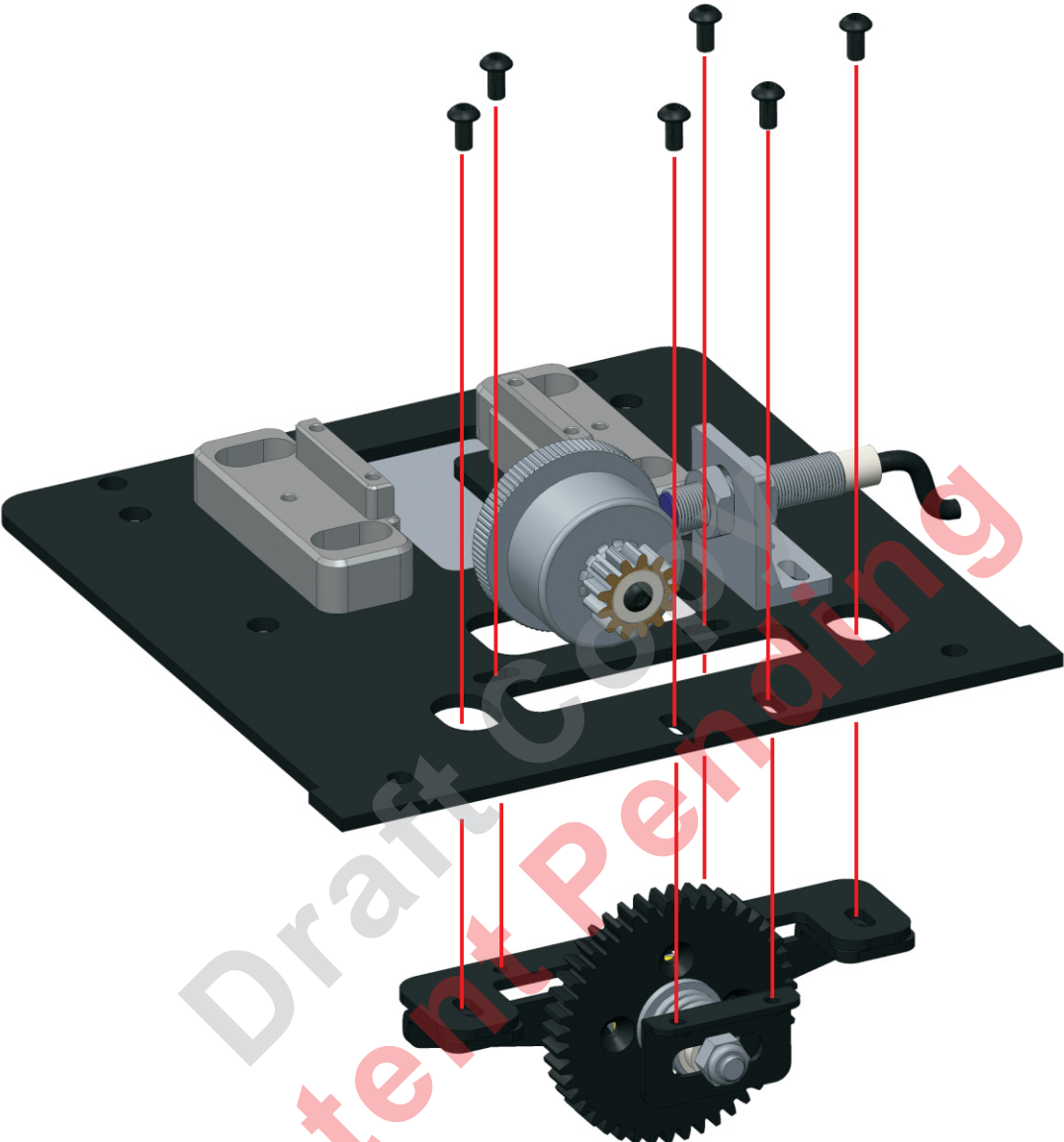

Free play Adjustment

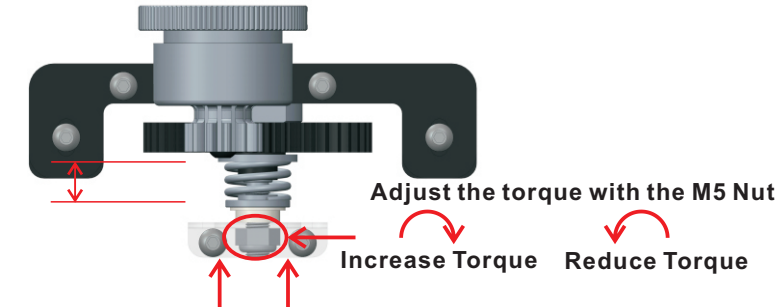

Fix the screw after torque adjustment completed

Loading Torque Adjustment

## 7、 Change to Manual Mode

7.1) . Press the Mode key once



7.2) . Press the reset key once



7.3) . Mode column on Display changed to "M"mode,with stop Flashing.

```
Mode : M Temp : 000.0°C
Thr . 0000 Speed:00000
Cycle : 1/4 Time : 00:00
Soft Version : 31.1
```

## 8、 Change to Mode 1,2,3 and 4

8.1) . To switch to any automatic mode must switch to manual mode only can be replaced.

8.2) . Press the Mode key once



8.3) . Press the reset key once



8.4) . Mode column on Display changed to "M"mode,with stop Flashing.

```
Mode : M Temp : 000.0°C
Thr . 0000 Speed:00000
Cycle : 1/4 Time : 00:00
Soft Version : 31.1
```

8.5) . Continue to press Mode Key 3 seconds.



8.6) . Mode column on Display changed to "M"mode,with Flashing.

```
Mode : M Temp : 000.0°C
Thr . 0000 Speed:00000
Cycle : 1/4 Time : 00:00
Soft Version : 31.1
```

8.7) . Press Up or Down Key to choose the mode you need.Mode column on display

change to selected mode with flashing



```
Mode : 1 Temp : 000.0°C
Thr . 0000 Speed:00000
Cycle : 1/4 Time : 00:00
Status : In Operation!
```

```
Mode : 2 Temp : 000.0°C
Thr . 0000 Speed:00000
Cycle : 1/4 Time : 00:00
Status : In Operation!
```

```
Mode : 3 Temp : 000.0°C
Thr . 0000 Speed:00000
Cycle : 1/4 Time : 00:00
Status : In Operation!
```

```
Mode : 4 Temp : 000.0°C
Thr . 0000 Speed:00000
Cycle : 1/4 Time : 00:00
Status : In Operation!
```

8.8) . Press Enter Key to confirm. The mode you selected will display and stop flashing.



8.9) . Change temperature display Unit.

8.9.1 This change must be performed in manual mode.

8.9.2 Press the "down" key once.



```
Mode : M Temp : 000.0°C
Thr . 0000 Speed:00000
Cycle : 1/4 Time : 00:00
Soft Version : 31.1
```

8.9.3 The temperature Unit "°C" or "F" will be flashing.

8.9.4 Press the "Up" key to choose the Unit.



```
Mode : M Temp : 000.0°F
Thr . 0000 Speed:00000
Cycle : 1/4 Time : 00:00
Soft Version : 31.1
```

8.9.5 Press the "Enter" key to confirm.





## 9. Advance parameter Setting (Skip this setting if using “factory default setting”)

### 9.1). HOW TO GO INTO PARAMETER SETTINGS MODE

Press and hold “Mode” and “Reset” button at the same time for 1 second, then release the “Reset” button while still holding the “Mode” button for 1 more second and then release the “Mode” button as well. The parameter setting manual settings will then display on the LCD Panel. The device will then be able to go into 5 windows of the parameter setting (as shown below).



Mode : 1 Cycles: 7 Cycles Time: 20Min Temp Low: 038C	Temp Halt : 120C Temp Start Fan : 098C Temp Stop Fan: 085C Temp Start Heat: 082C	Temp Stop Heat : 080C Temp Motor On : 090C RPM Req Motor: 08000 RPM Max Motor: 12000	CA1 T:01.0s PWM:1530 CA2 T:00.0s PWM:1500 CA3 T:00.0s PWM:1500 CA4 T:00.0s PWM:1500
CA5 T:00.0s PWM:1500			

### 9.2). HOW TO SET THE PARAMETERS

To navigate to the next window, keep pressing the down cursor button until the window changes to the next one. Use the + and - cursor buttons to change the individual settings. Once you are finished changing your settings, press the save key.

### 9.3). Keys definition:

< UP >	Cursor UP
< DOWN >	Cursor Down
< LEFT >	Cursor Left
< RIGHT >	Cursor Right
< HEATER (+) >	Increase
< DRIVE MOTOR (-) >	Decrease
< SAVE >	Save the setting

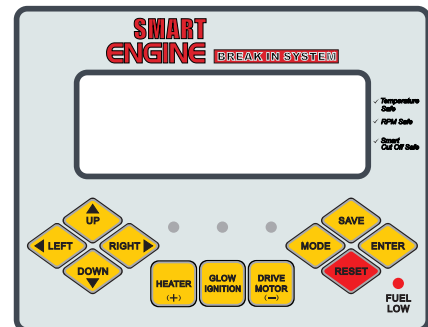

### 9.4). Parameter Definition:

< Mode >	Program mode (1-4 mode)
< Cycle >	Cycles for each program (1-9 cycle)
< Cycles Time >	Running “period” for each cycle (1-99 minute)
< Cooling Stop >	Cooling fan “stop” once the engine temperature cool reduced to (1-99 C)
< Over Heat cutoff >	Engine overheat “cutoff” temperate (1-150 C)
< Cooling On >	Cooling fan “working” temperate during operating (1-150 C)
< Cooling Off >	Cooling fan “stop working” temperature during operating (1-150 C)
< Heat On >	Heater unit “turn on” temperature during operating (1-150 C)
< Heat Off >	Heater unit “turn off” temperature during operating (1-150 C)
< Per Heat Temp >	Preheating temperature for engine before star (1-150 C)
< Idling RPM >	Engine idling RPM during operating (4000-36000 RPM)
< RPM Cutoff >	Engine RPM overrun “cutoff” during operating (4000-36000 RPM)

### 9.5) . HOW TO SET MODE 3 AND 4 THROTTLE CURVE WITH 5 POINTS

Go to T at CA1 Parameter Setting and set the timing (Range = 1ms – 100ms) and go to CA1's PWM to set the throttle's value (Range = 800PWM – 2200PWM). Do this accordingly for CA2 then CA3 then CA4 and lastly CA5.

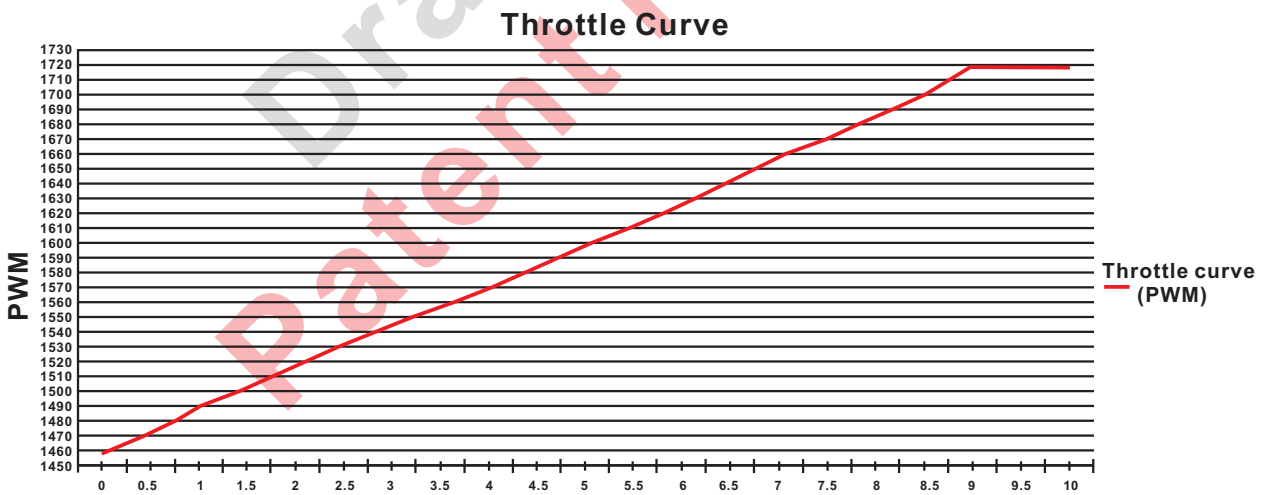
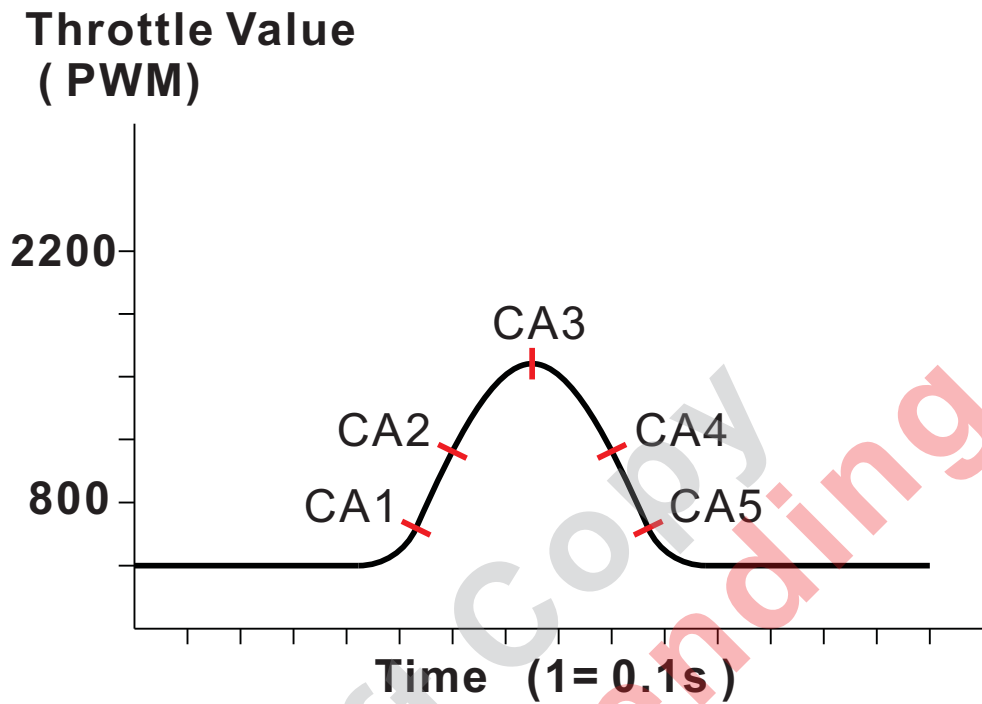

Venture valve (mm)	0	0.5	1	1.5	2	2.5	3	3.5	4	4.5	5	5.5	6	6.5	7	7.5	8	8.5	9	9.5	10	
Venture valve (%)	0%	8%	17%	25%	33%	42%	50%	58%	67%	75%	83%	92%	100%									
Throttle movement by step PWM	0	20	39	53	66	80	93	105	117	131	144	158	171	187	202	215	228	245	261	261	261	
Throttle curve (PWM)	1458	1475	1497	1510	1524	1538	1551	1562	1575	1588	1602	1615	1629	1645	1660	1672	1686	1700	1719	1719	1719	1719

**Throttle movement Vs engine carburetor movement reference data**

- < CA1 > Throttle timing from starting point to CA1 (1-100 mS)
- < PWM > Throttle value from idling point to CA1 (800-2200 PWM)
- < CA2 > Throttle timing from CA1 to CA2 (1-100 mS)
- < PWM > Throttle value from CA1 to CA2 (800-2200 PWM)
- < CA3 > Throttle timing from CA2 to CA3 (1-100 mS)
- < PWM > Throttle value from CA2 to CA3 (800-2200 PWM)
- < CA4 > Throttle timing from CA3 to CA4 (1-100 mS)
- < PWM > Throttle value from CA3 to CA4 (800-2200 PWM)
- < CA5 > Throttle timing from CA4 to CA5 (1-100 mS)
- < PWM > Throttle value from CA4 to CA5 (800-2200 PWM)

If the total amount of time set for CA1 up to CA5 and the starting idling value is less than 15s, the system will add an idling value to add it up the total to 15s. After this is done, press the "Save" button.

Finished the setting, Press the "SAVE" key.

- 9.6) . If the displays says "Save Finished", it means you have done it correctly.

Save Finished

- 9.7) . If the display says "Error: LOGIC!" it means you have set the parameters wrongly as shown below.

- CA1+CA2+CA3+CA4+CA5 >=15s
- Cooling Stop < Over Heat cutoff
- Cooling Stop < Cooling On
- Cooling Stop < Cooling Off
- Cooling Stop < Heat On
- Cooling Stop < Heat Off
- Cooling Stop < Per Heat Temp
- Cooling On >= Over Heat cutoff
- Cooling On <= Cooling Off
- Cooling On <= Heat On
- Cooling On <= Heat Off
- Cooling Off >= Over Heat cutoff
- Cooling Off <= Heat On
- Cooling Off < Heat Off
- Per Heat Temp > Over Heat cutoff

Error : LOGIC!

- 9.8) . If the display says "Error: Out Of Range!" it means that the value you have inserted exceeds the parameter range given.

Error : Out of Range!

- 9.9) . Press the left and right key at the same time, and whilst holding the two keys, press the reset key to reset the parameter settings to default setting. The default setting is as shown below.

Model 1:

< Mode >	1	< RPM Cutoff >	12000
< Cycle >	4	< CA1 >	0
< Cycles Time >	15	< PWM >	1500
< Cooling Stop >	40	< CA2 >	0
< Over Heat cutoff >	105	< PWM >	1500
< Cooling On >	95	< CA3 >	0
< Cooling Off >	90	< PWM >	1500
< Heat On >	88	< CA4 >	0
< Heat Off >	90	< PWM >	1500
< Per Heat Temp >	90	< CA5 >	0
< Idling RPM >	8000	< PWM >	1500

<b>Model 2:</b>			
< Mode >	2	< RPM Cutoff >	13000
< Cycle >	4	< CA1 >	0
< Cycles Time >	15	< PWM >	1500
< Cooling Stop >	40	< CA2 >	0
< Over Heat cutoff >	105	< PWM >	1500
< Cooling On >	95	< CA3 >	0
< Cooling Off >	90	< PWM >	1500
< Heat On >	88	< CA4 >	0
< Heat Off >	90	< PWM >	1500
< Per Heat Temp >	90	< CA5 >	0
< Idling RPM >	9000	< PWM >	1500

<b>Model 3:</b>			
< Mode >	3	< RPM Cutoff >	20000
< Cycle >	4	< CA1 >	5
< Cycles Time >	15	< PWM >	1575
< Cooling Stop >	40	< CA2 >	1
< Over Heat cutoff >	120	< PWM >	1500
< Cooling On >	95	< CA3 >	4
< Cooling Off >	90	< PWM >	1535
< Heat On >	88	< CA4 >	5
< Heat Off >	90	< PWM >	1536
< Per Heat Temp >	90	< CA5 >	5
< Idling RPM >	8000	< PWM >	1510

<b>Model 4:</b>			
< Mode >	4	< RPM Cutoff >	20000
< Cycle >	4	< CA1 >	5
< Cycles Time >	15	< PWM >	1575
< Cooling Stop >	40	< CA2 >	1
< Over Heat cutoff >	125	< PWM >	1545
< Cooling On >	95	< CA3 >	4
< Cooling Off >	90	< PWM >	1575
< Heat On >	88	< CA4 >	5
< Heat Off >	90	< PWM >	1576
< Per Heat Temp >	90	< CA5 >	5
< Idling RPM >	8000	< PWM >	1550

9.10) . Once you have completed all this, press the power down or reset key to restart the system.

## 10. Reset Function / Last memory Save

### A. Press the Enter key once

When an error occurs during operation, press the Enter Key. The machine will continue to execute the unfinished program.

### B. Press the Reset key once

When an error occurs during operation, press the Reset Key. The machine will completely reset and restart the program.

### C. Pressed the "SAVE" button on the panel before switch off the machine, the machine will memory the status of the currently running process. ( the remaining CYCLES, the current CYCLES remaining time ) when the power is turned on again, the last memory parameters are restored.

Remark : When Glow ignition indicator blinking, please make sure the glow plug wire is connected with intact glow plug.

# 11. Starter Rubber Gap between Flywheel Adjustment

(This adjustment applies only when starter rubber wear and tear occurs.)

- 1) . Press the Up Key and Enter Key at the same time. Mode column on Display changed to Mode "CF" with PWM indication and starter rubber will go to original position

automatically.  + 

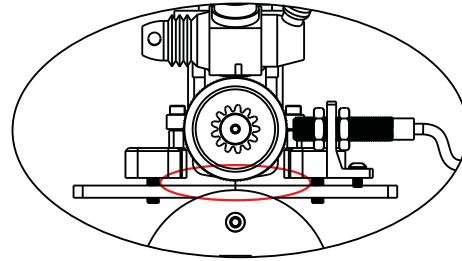
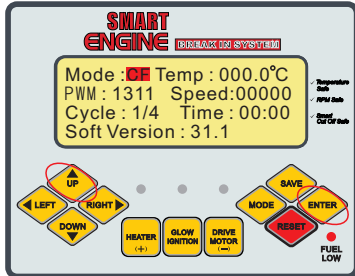

Fig A

- 2) . Press The Up Key or Down Key to adjust the starter rubber to touch the flywheel. When turn the flywheel will feel a little friction with the starter rubber.

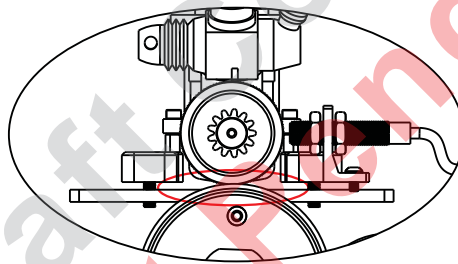
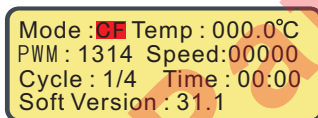
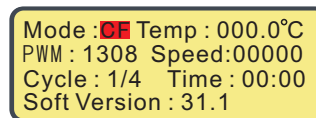

Fig B

- 3) . The Display column PWM will increase with Up Key and reduce with Down Key. (3PWM per Step).



Up key



Down key

- 4) . Press Enter key to confirm and the machine will back to manual mode automatic.

# 12. Fuel Refill

- 1) . Close Stoper "A" , "B" and Open Stoper "C".
- 2) . Press "Fuel Pump key" and "In Key" at the same time. (More than 1 Sec.)
- 3) . Once the Fuel tank is full, Press "Fuel Pump key" and "In Key" at the same time.(More than 1 Sec.)
- 4) . Remove the fuel from the tank, Will be same step as above, with "Out Key" to replace the In Key.

Remark :

When Fuel low indicator continue on more then 3 minute engine will automatic stop by break system.



## **13. Setup your engine with Manual mode before using automatic mode break in your engine.**

- 1) . Remove the original heat sink from the engine and replace with heater unit.
- 2) . Fix the Flywheel and clutch unit on the engine.
- 3) . Install the engine on engine mount and connect the glow wire to the plug.
- 4) .Adjust the engine mount and break system position.
- 5) .Install the exhaust pipe and connect the press throat.
- 6) .Adjust the starter rubber centering position.
- 7) .Adjust the RPM sensor gap.
- 8) .Install the loading unit.
- 9) .Connect the power supply to the machine.
- 10) .Turn On the main power switch.
- 11) .Change the machine to Mode 'M" .(Manual mode)
- 12) .Make sure the machine is under Mode"M".
- 13) .Adjust the throttle and break linkage traveling with original idling setting.
- 14) .Press Heater ON/OFF key once to switch on the heater. (Heater indicator On)
- 15) .Once the temperature up to 85°C turn off the heater by press Heater ON/OFF key once. (Heater indicator Off)
- 16) .Press the Glow Ignition ON/OFF key to turn on the glow plug.  
(Glow Ignition indicator On)
- 17) .Press and hold the Drive Motor key to star the engine.
- 18) .Once the engine star running, release the Drive Motor key immediately.
- 19) .Turn off the glow plug by press the Glow Ignition ON/OFF key.  
(Glow Ignition indicator Off)
- 20) .Adjust the idling RPM about 7500-8000.
- 21) .Fine tune the throttle linkage stopper space.
- 22) .Once setup complete, stop the engine manually.
- 23) .Now you can change to auto mode star to break in your engine.

### **Excluding items:**

- Power supply
- Engine
- Exhaust pipe
- Clutch shoe and Clutch bell set
- Fuel Pump

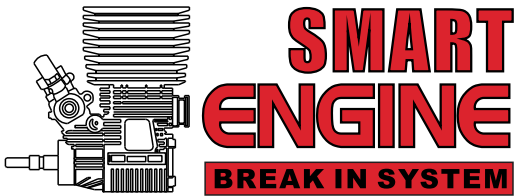

## MegaLoad Installation Instructions

- 1: Insert CD into your computer drive
- 2: Click "[setup.msi](#)" to install
- 3: If you are prompted to install the "microsofte framework" during installation, please exit the installation and install the Microsoft .NET Framework 2.0.50727 Redistributable directly on the CD-ROM.
- 4: When the microsofte framework is installed, please install Megaload([setup.msi](#)) again.
- 5: Please connect USB-RS232 Cable (USB-serial) when all installations are completed
- 6: If your computer does not recognize this USB-RS232 Cable (USB-serial). Please install the driver for this cable "[driver usb-serial port](#)" from CD)
- 7, when all the above installation is completed, run "MegaLoad" and ready to upgrade the latest firmware.

## Upgrade the Firmware

1. Turn OFF the machine and connect the serial port (RS232) on the back of the machine to your PC via serial data cable
2. First, power off the machine and open the [Megaload.NET](#) software on your computer. Set the following settings (refer to the following figure for specific settings):
3. In the "[File to be programed in the Flash](#)" column, open the program's directory.
4. Select the port in the "[Commport](#)" column to **ComPort**, select the speed in the "[Speed](#)" column to **9600bps**.
5. Click "[Open Port](#)" change to **Close Port**.
6. Turn on the power switch at the back of the machine. At this time, the Messages column will display the upgrade information. After the upgrade, **Flash Prog Done** will be displayed on "[Status](#)" column, **Successful finished** and **waiting for next target** will be displayed on "[Message](#)" column. This indicates that the upgrade is complete.
7. Unplug the serial data cable from the serial port (RS232) and mechanic is ready to operate with latest firmware.

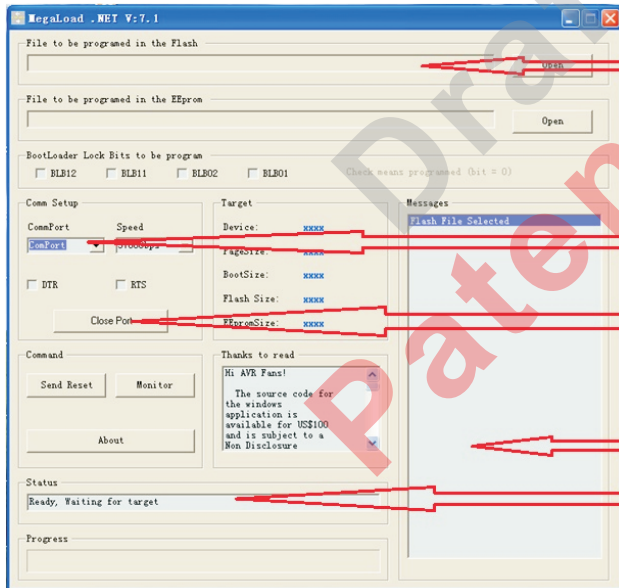
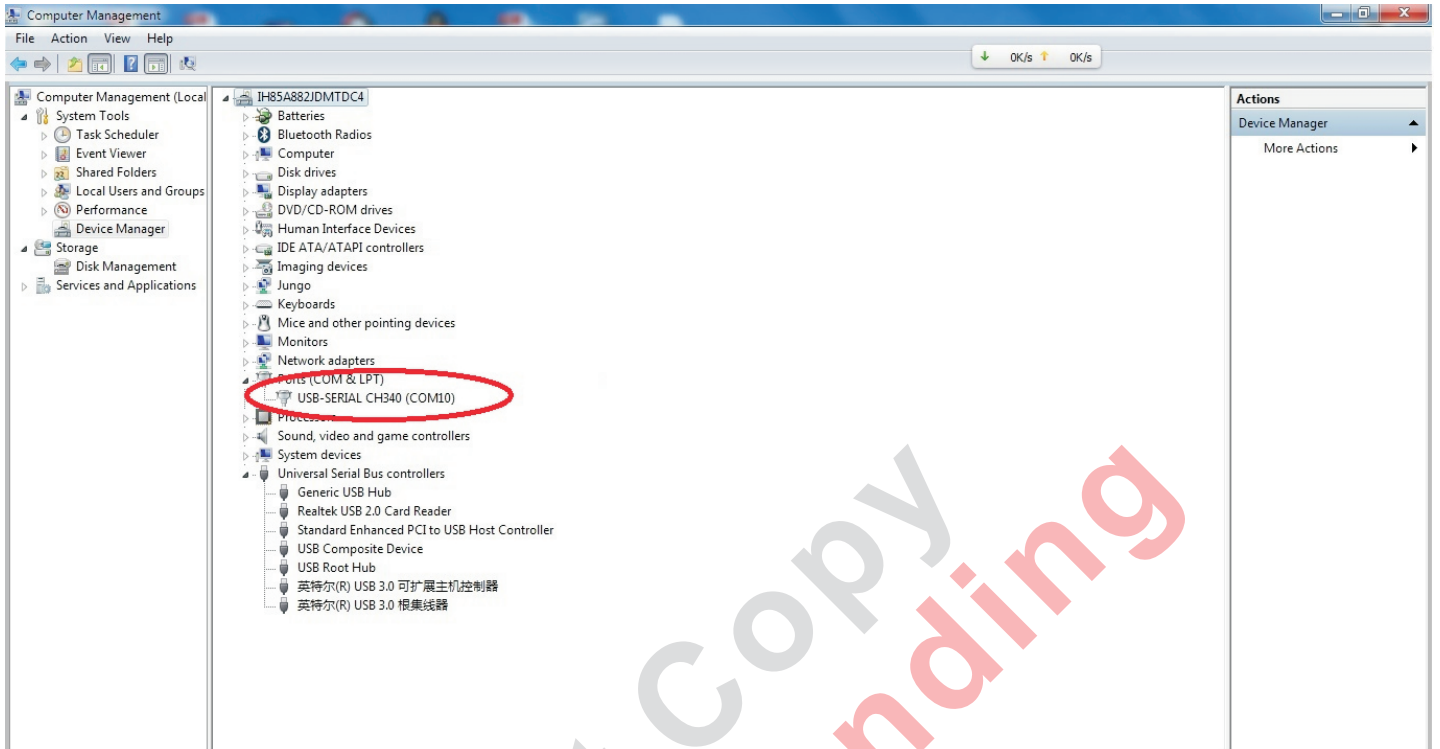

# MEMO

**SMART  
ENGINE**  
BREAK IN SYSTEM

MODEL  
NUMBER 336LCD

Rev : 5.2

 **SMART-WORKSHOP**  
*Turning ideas into reality*

Design and Manufacturer by SMART-Workshop  
[WWW.smart-workshop.org](http://WWW.smart-workshop.org)