

# INSTRUCTION MANUAL

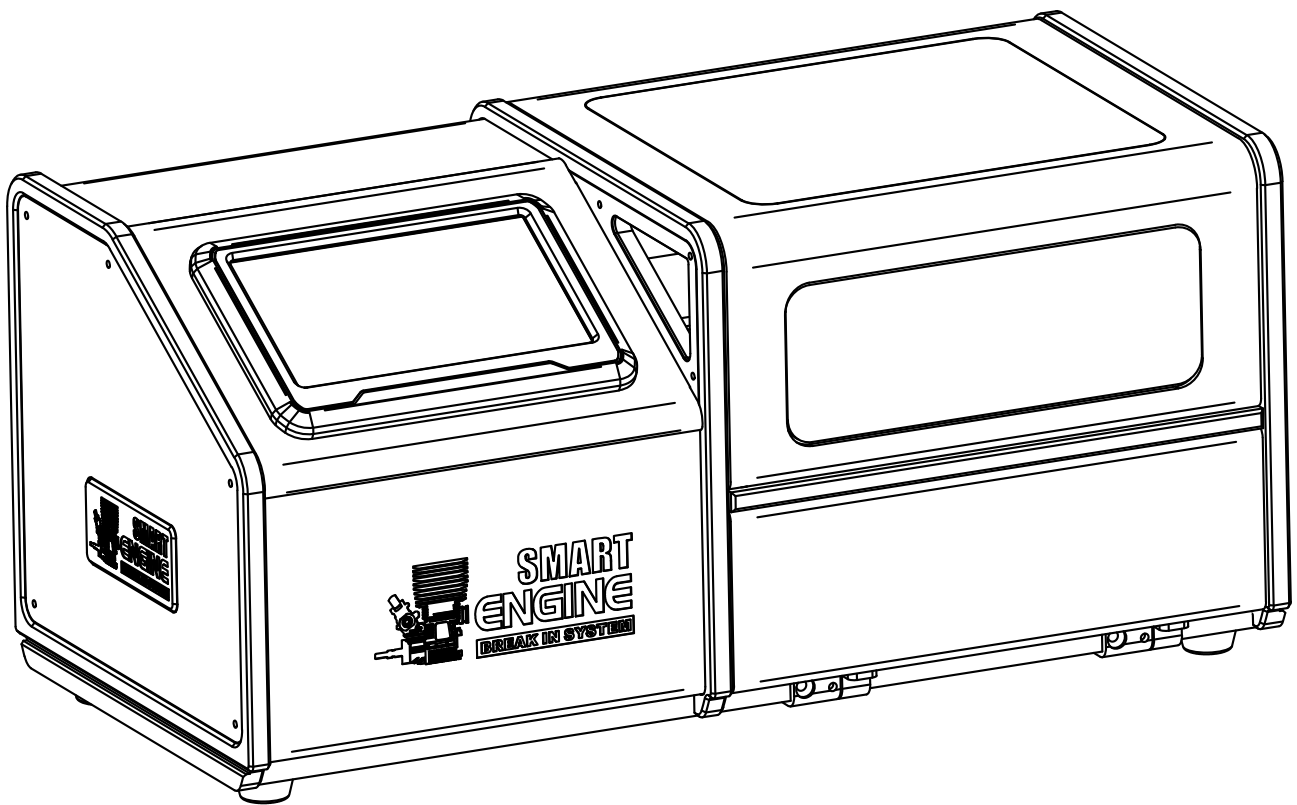

# Menu

---

- 1 - 3 ..... Item List
- 4 - 6 ..... Product Guide
- 7 - 8 ..... Fuel Line Diagram - Oil Running
- 9 - 12 ..... Page Naming
- 13 - 15 ..... Parameter Explain
- 16 - 27 ..... Start With Oil Running
- 28 - 29 ..... Spring Tension Installation
- 30 - 40 ..... Start With Oil Bath
- 41 - 43 ..... Withdraw Oil
- 44 - 55 ..... Switch to Oil Bath Module
- 56 - 66 ..... Switch to Oil Running Module
- 67 ..... How to open Oil Filter

# Item List

---

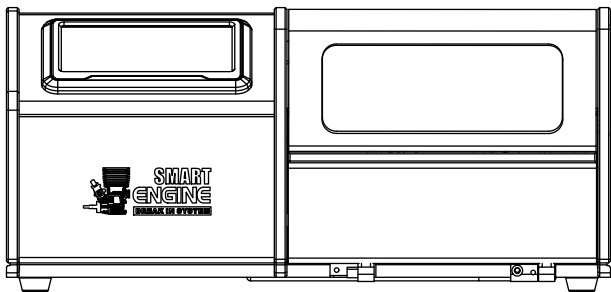

Lapping System x 1

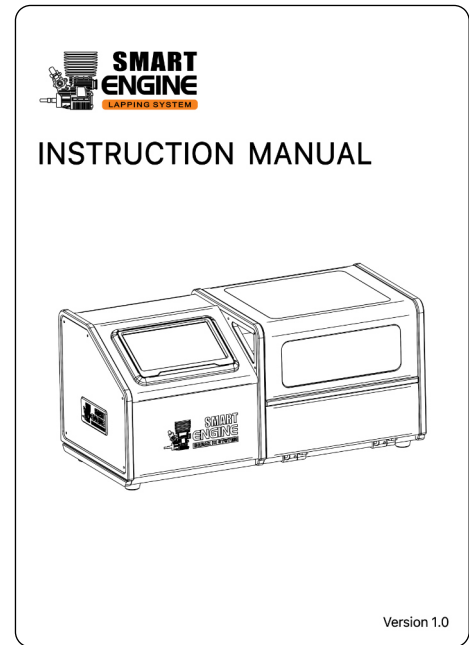

Instruction Manual x 1

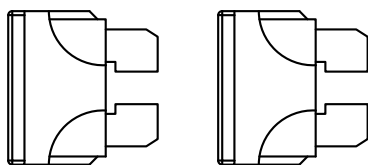

Spare Fuses

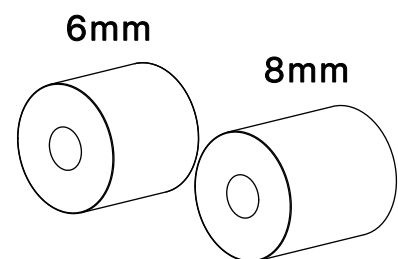

Crankshaft Spacer

# Item List

---

## Oil Running

Heatsink With Heater X 1

Engine Mount Spacer (0.5mm, 1mm & 2mm) X each 1  
**2mm spacer mounted on machine**

Oil Tube 0.5m (For Pump In/Out use) X 1

Oil Tube Clip (For Pump In/Out use) X 1

Straight Oil Tube Connector X 1 (Spare)

Horizontal Oil Tube Connector X 1 (Spare)

Top Outlet X 1

Shaft Coupling X 1

Crankshaft Spring Tension Set X 1

Rubber Seal X 1

.21 Exhaust Outlet X 1

.21 Inlet (15mm) X 1

.21 Inlet (13.85mm) X 1

Oil Tank Pressure Control Nut - Black X 1

Oil Tank Pressure Control Nut - Green X 1

Oil Tank Pressure Control Nut - Red X 1

.12 Exhaust Outlet - options X 1

.12 Inlet (13mm) - options X 1

.12 Inlet (12mm) - options X 1

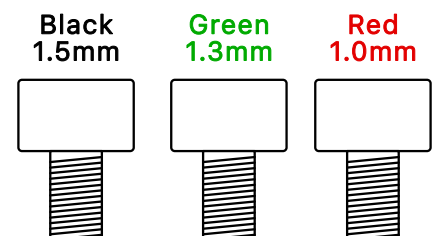

# Item List

---

## Oil Bath

Sleeve Holder With Washer X 1

Engine Mount Spacer (0.5mm, 1mm & 1.5mm) X each 1  
**1.5mm spacer mounted on machine**

Shaft Coupling X 1

Oil Seal X 1 (Spare)

O-Ring X 2 (Spare)

# Product Guide

---

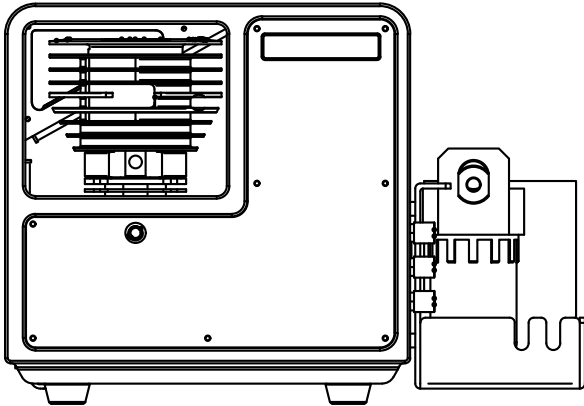

Touch Panel

Safety Cover

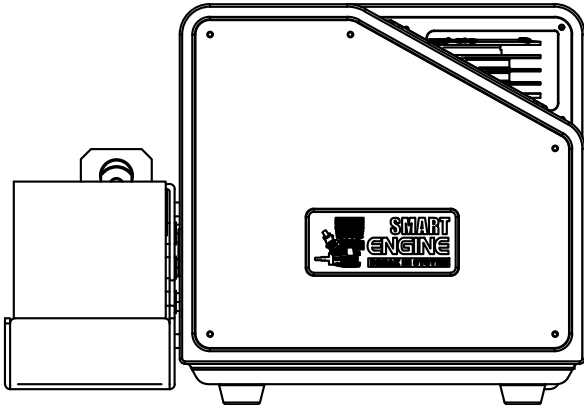
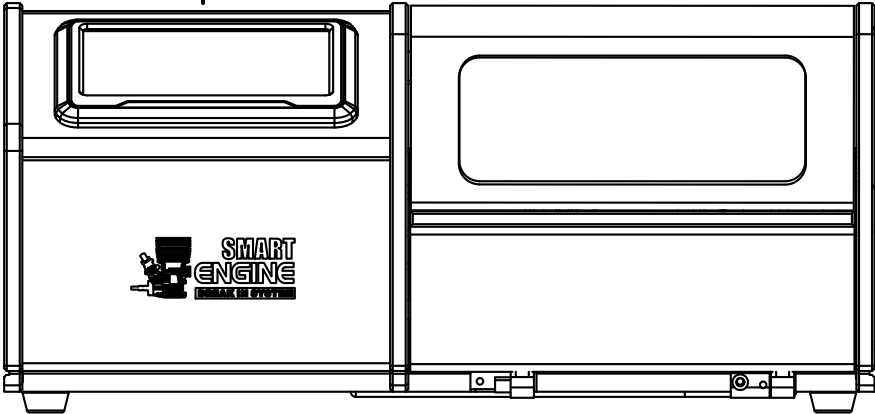

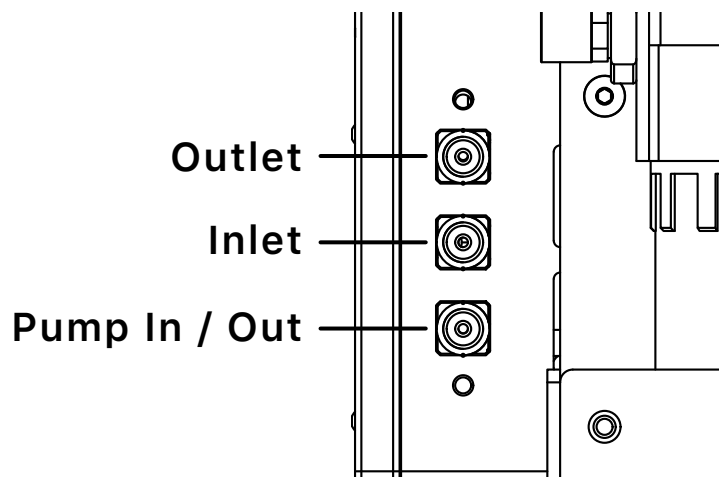
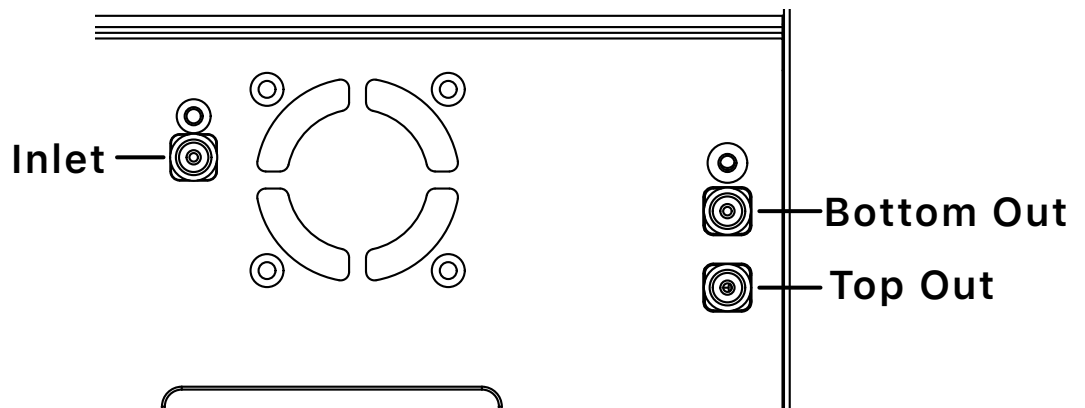
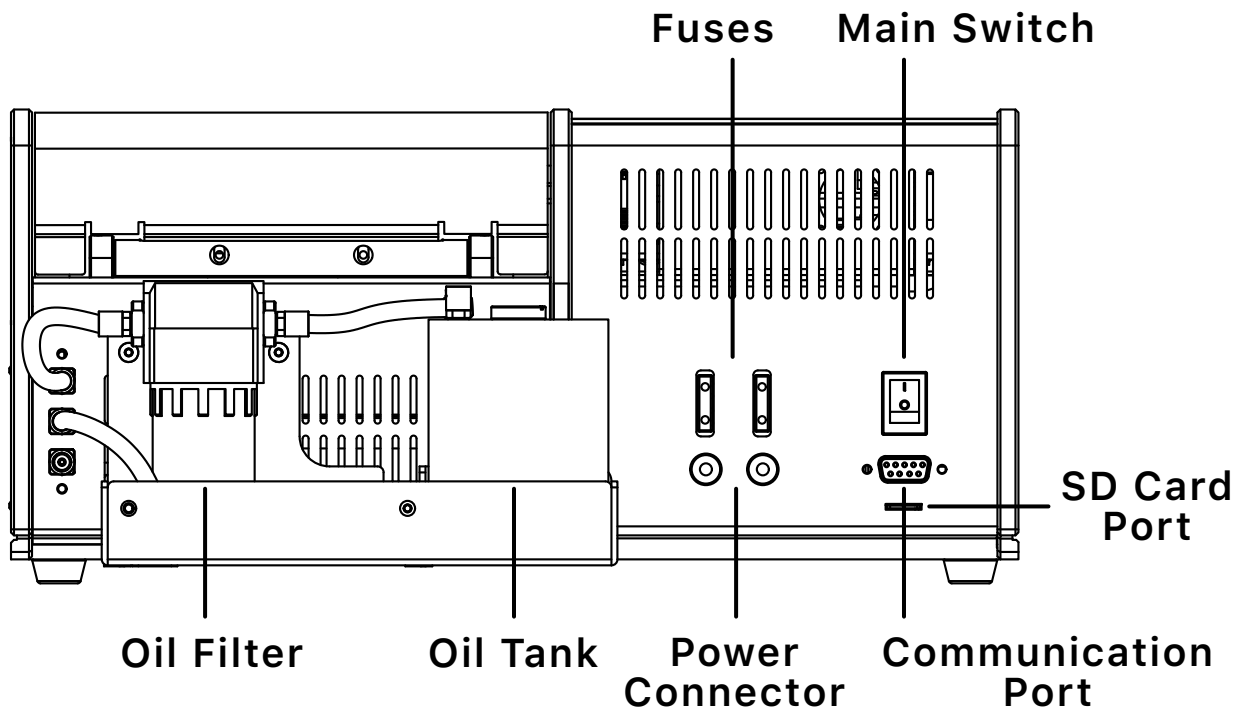

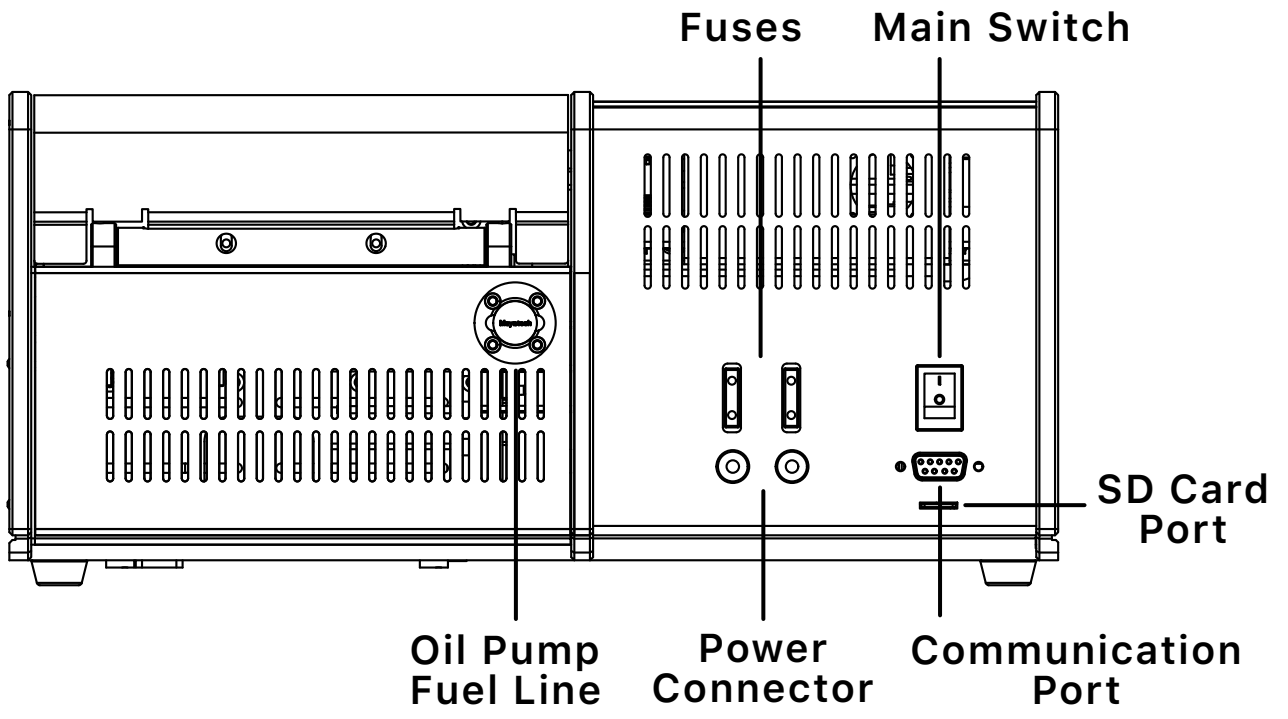



# Fuel Line Diagram - Oil Running

---

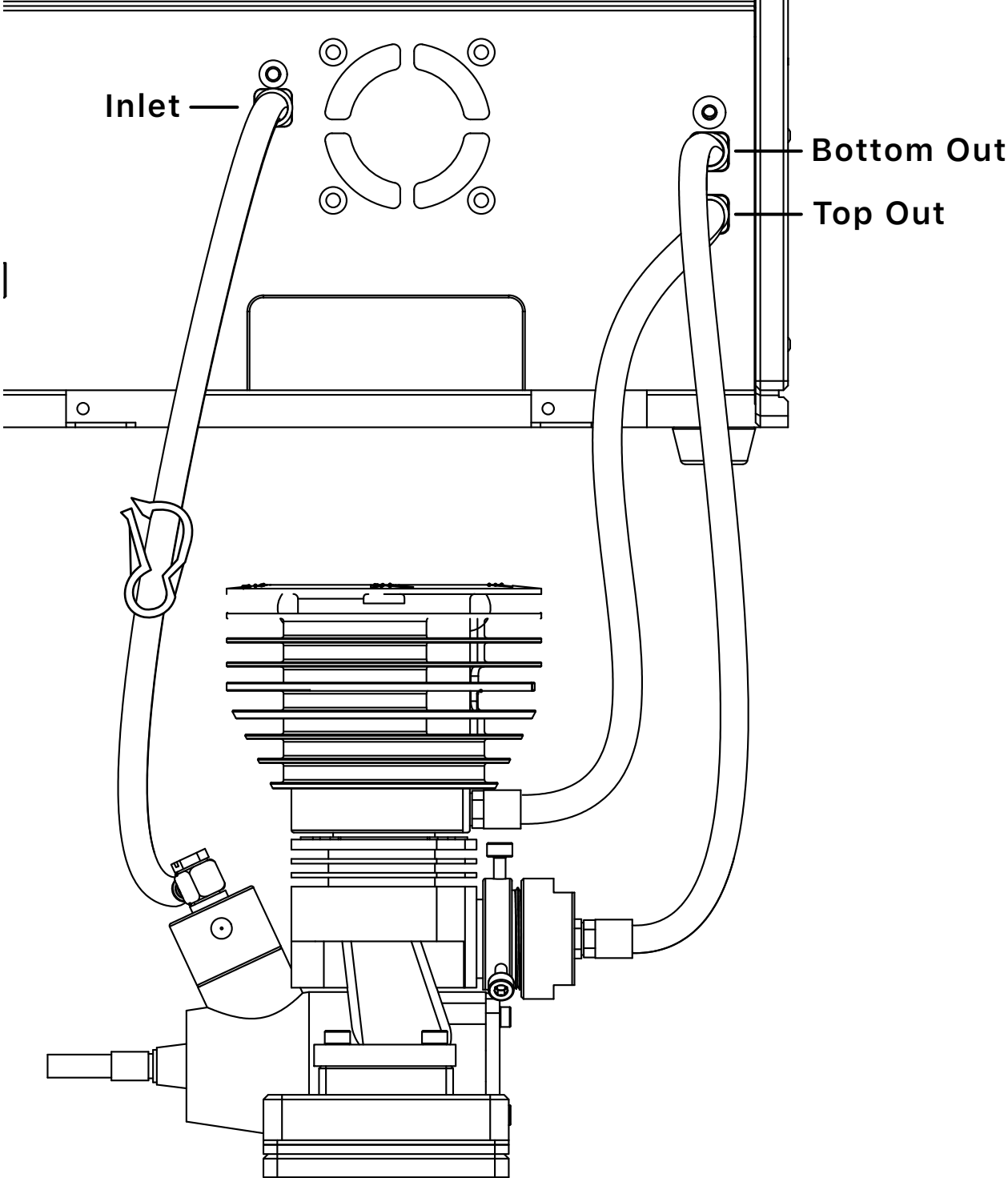

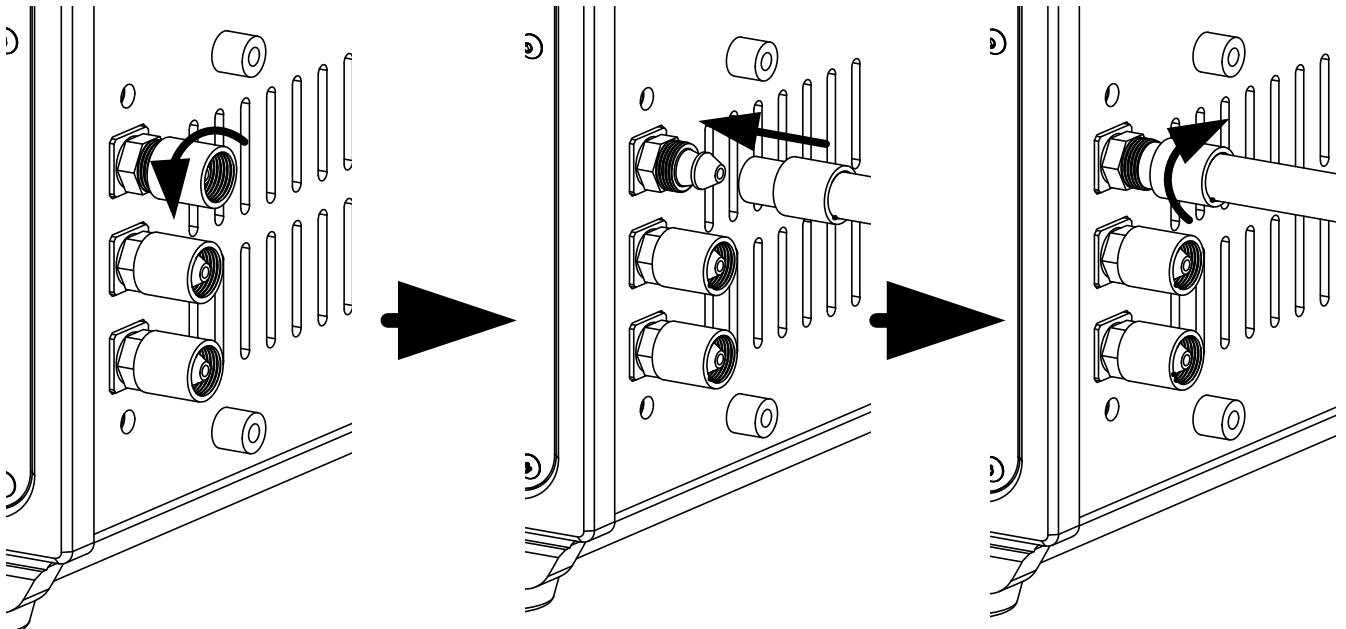
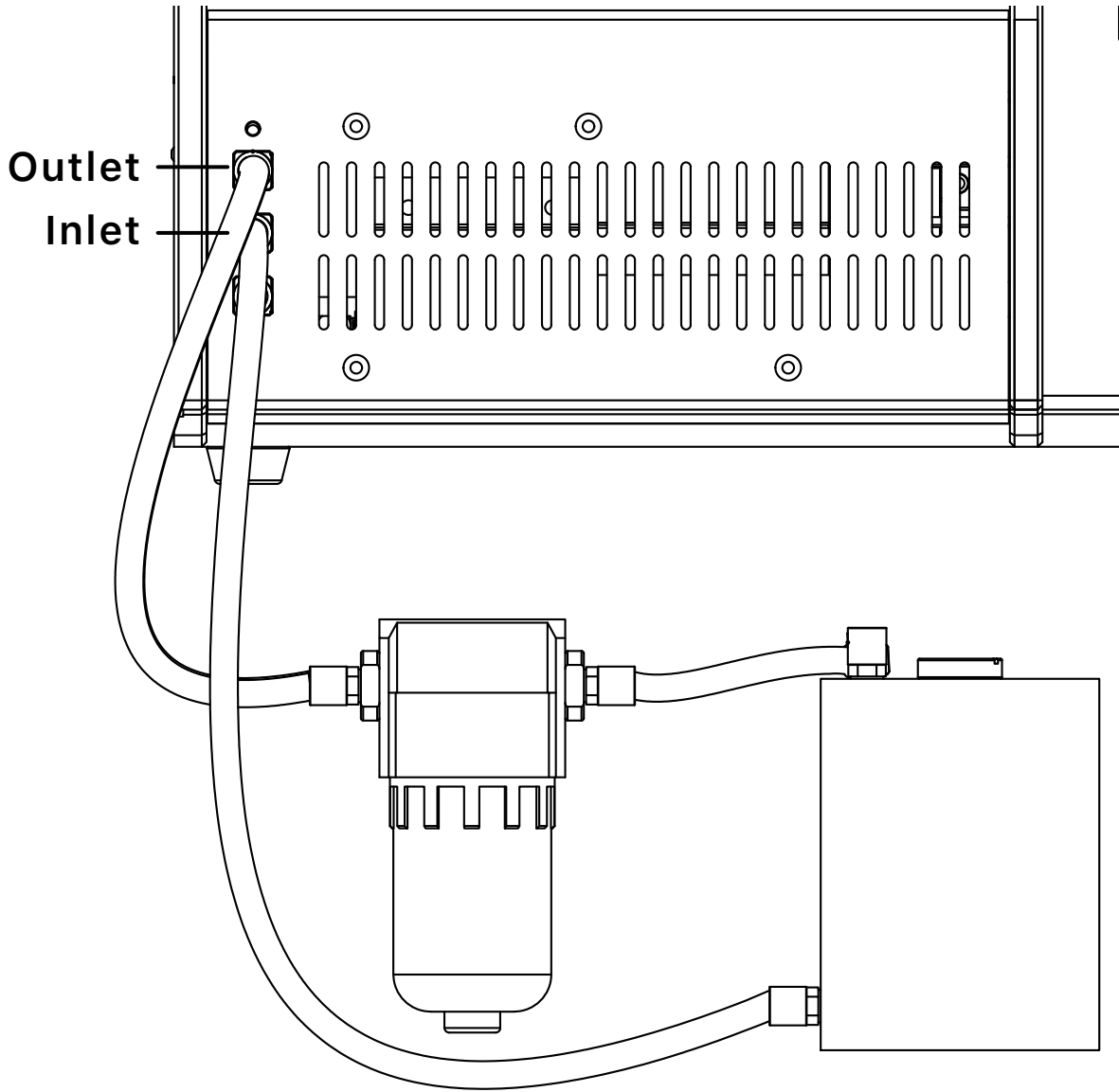

# Page Naming

---

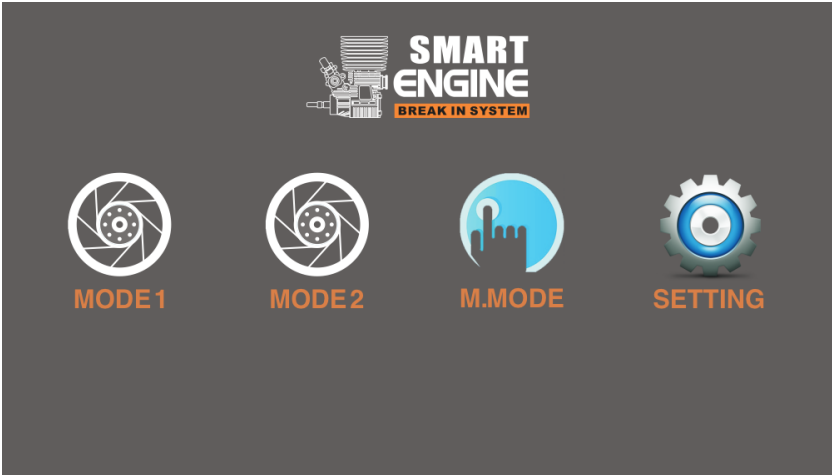

Home



Setting Menu

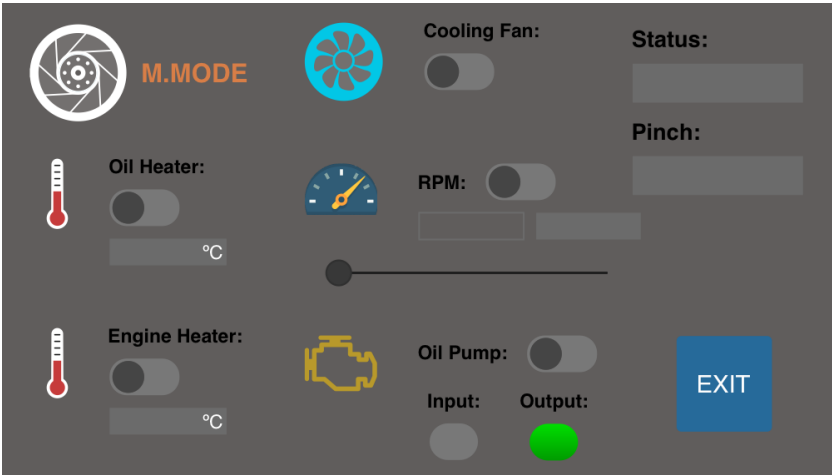

Manual Mode

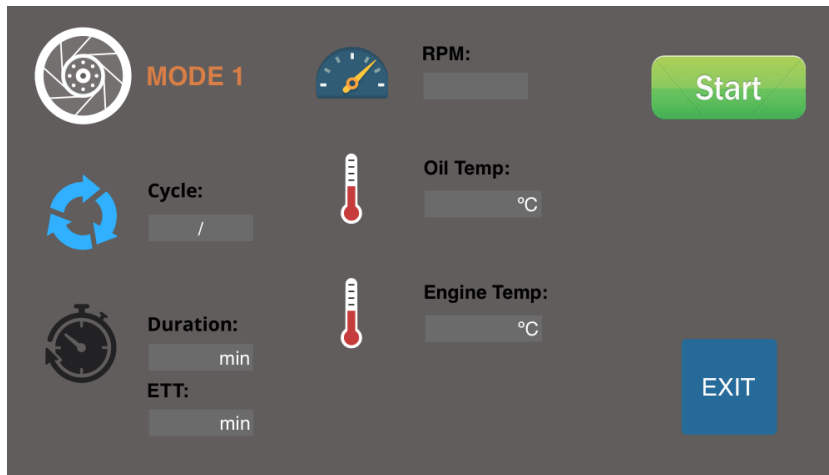

Mode 1 / 2

Pinch value is just for reference

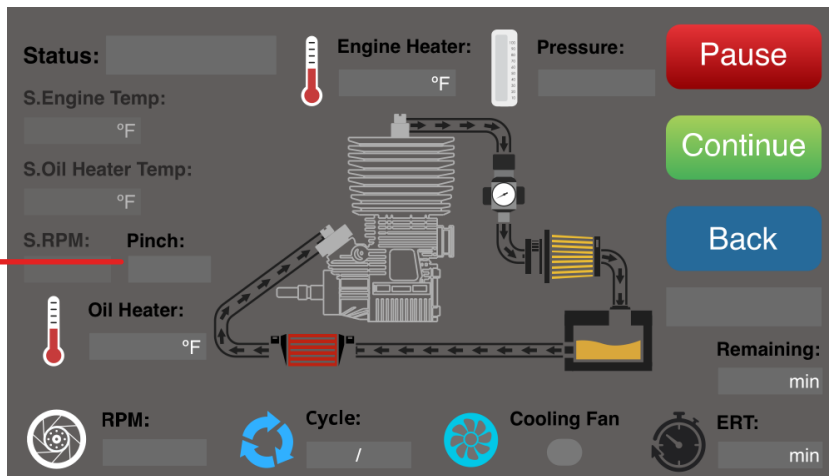

Operating Page - Oil Running

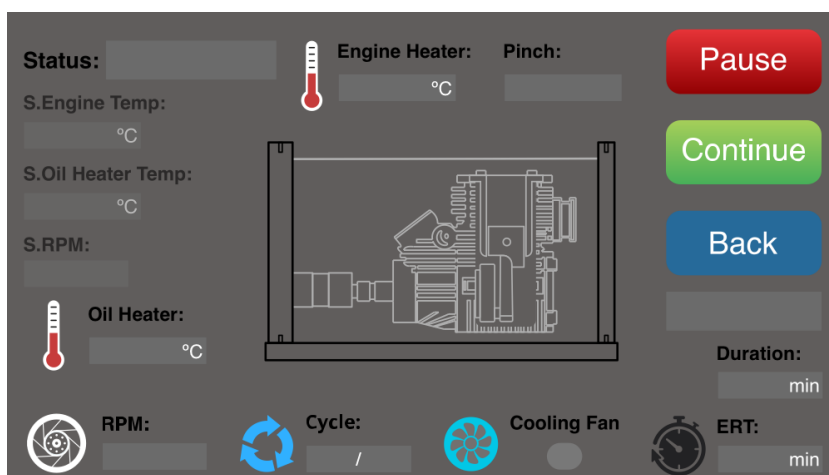

Operating Page - Oil Bath

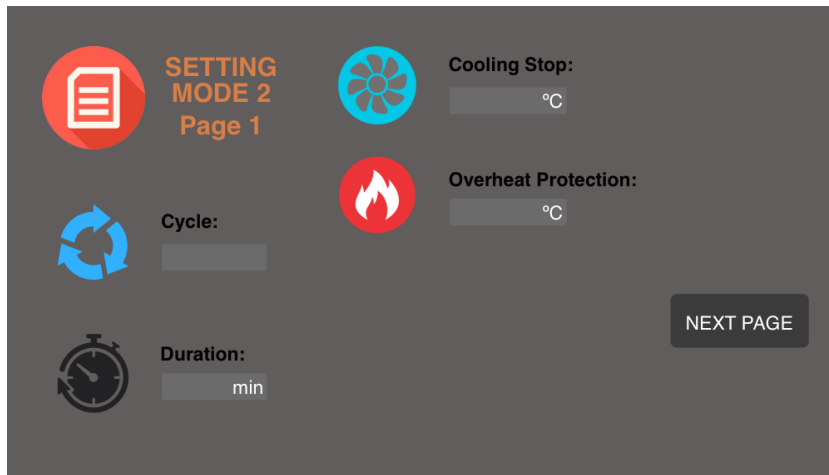

Setting Page 1

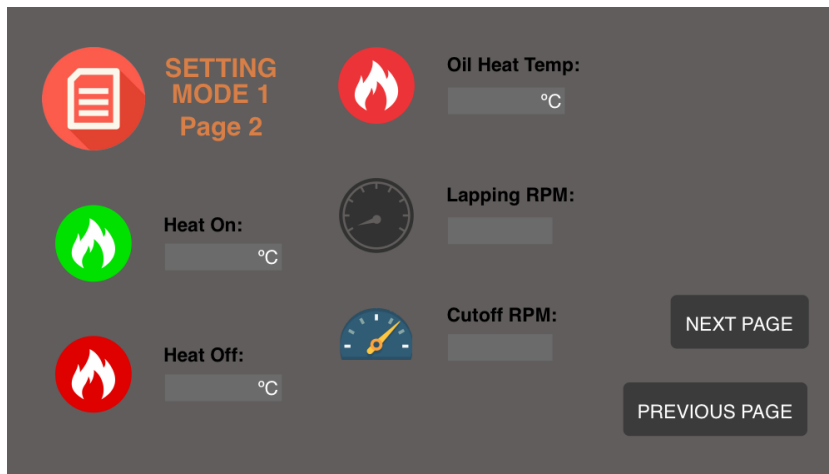

Setting Page 2

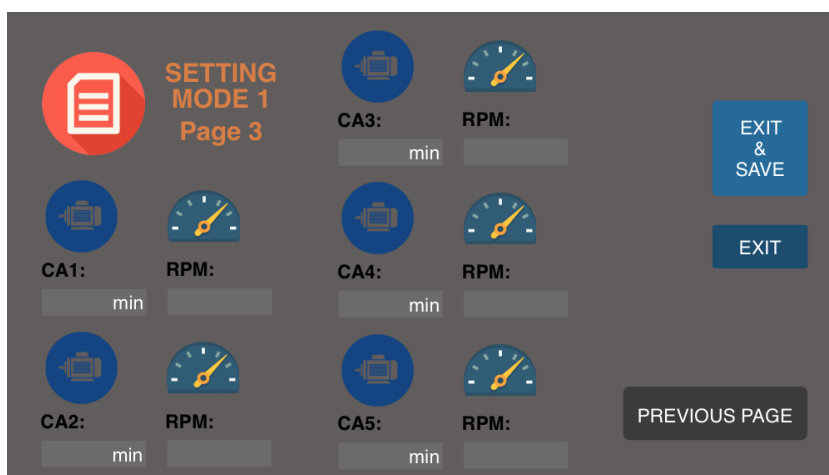

Setting Page 3 (Only In Mode 1)

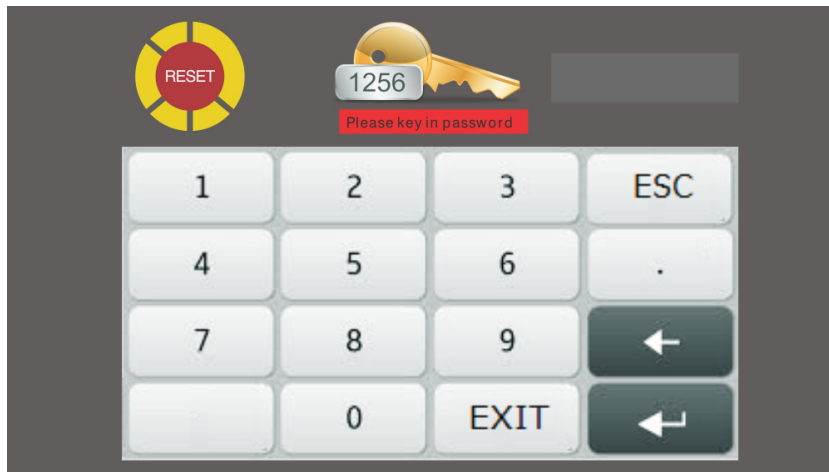

Reset Page

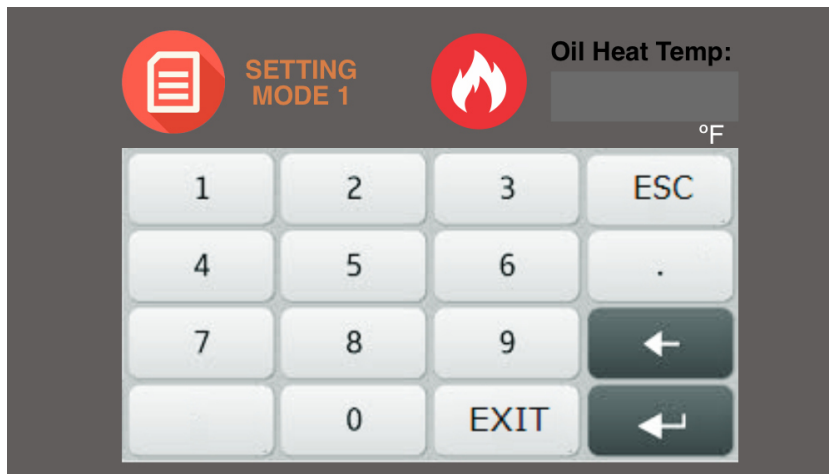

Parameter Key In Pages

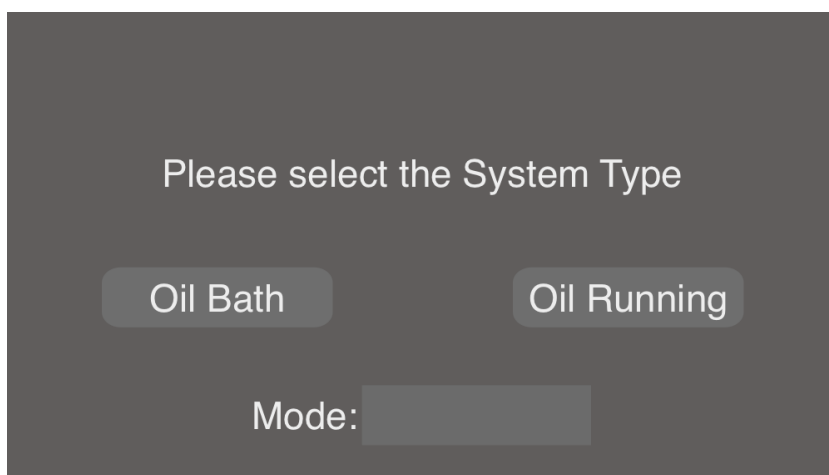

Factory Setup Select Page

# Parameter Explain

---

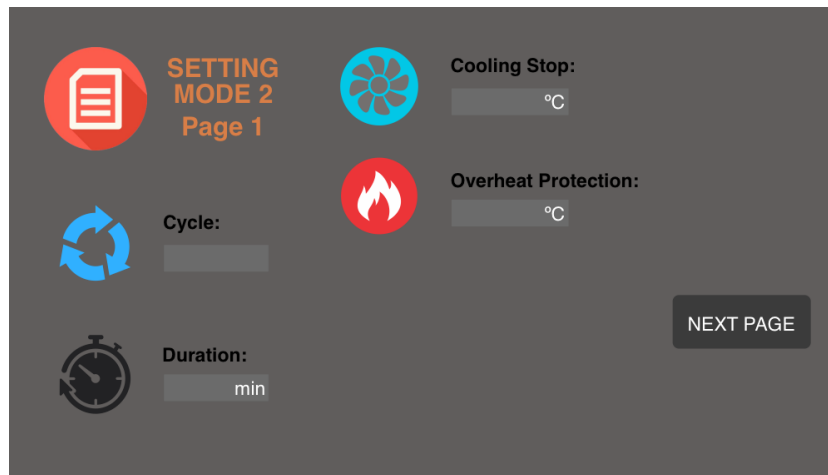

## Cycle

- The numbers of run with same parameter and Mode

## Duration

- The Duration of each Mode

## Cooling Stop

- Fan will stop working when engine drop to this temperature

## Overheat Protection

- The system will stop operating when engine over the temperature

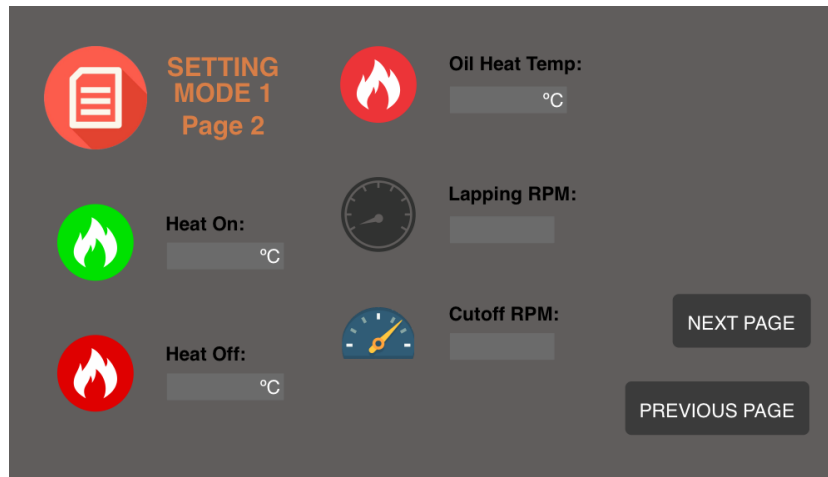

## Heat On

- Heater will start heat up engine when engine temperature drop to this parameter

## Heat Off

- Heater will stop heat up engine when engine temperature reach this parameter

## Oil Heat Temp

- The system will keep oil temperature according to the parameter

## Lapping RPM

- The constant lapping RPM that you would like to use for your engine

## Cutoff RPM

- System will stop operating when the RPM over this parameter



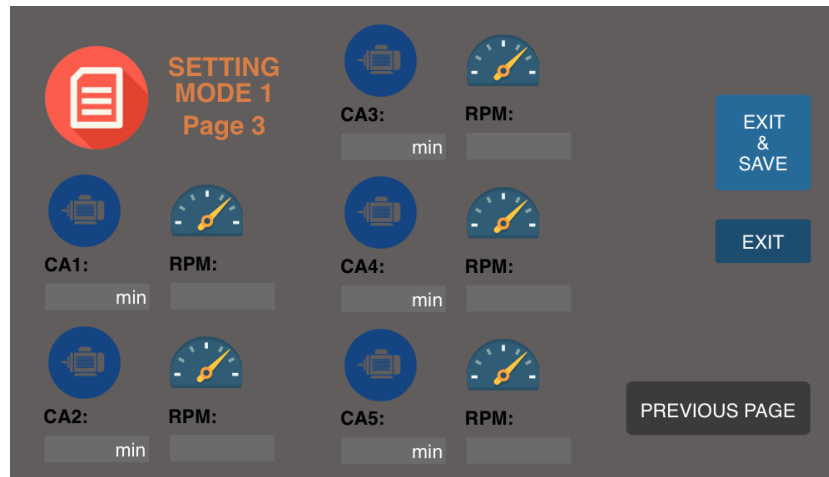

## CA1 - 5

- CA is represent the stages of each RPM. The Time and RPM can be variant in each CA.

## Min

- The duration of the CA in Minute. The sum of CA1 to CA5 will be the total cycle time.

## RPM

- The RPM of the CA

# Start With Oil Running

---

1

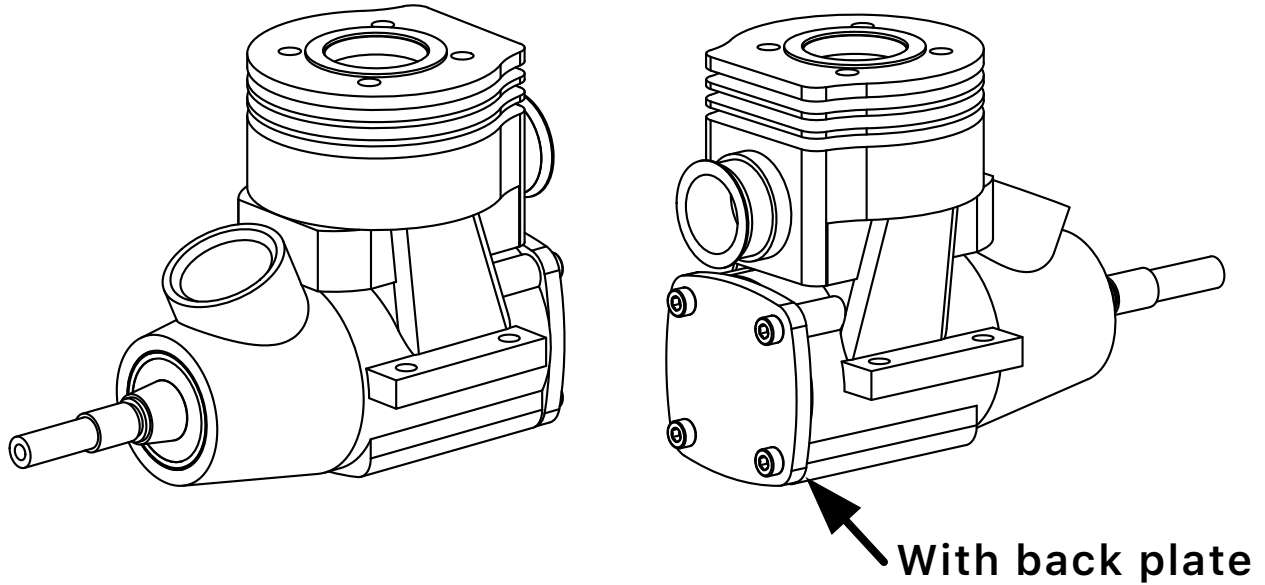

2

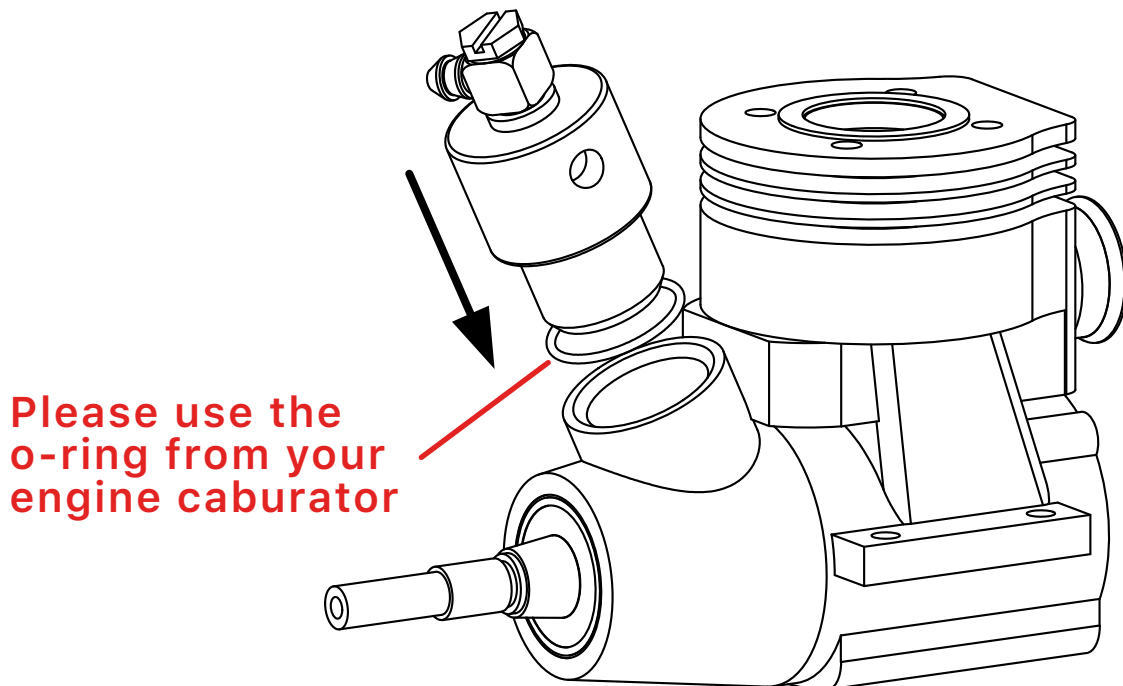

3

Please use a shim from your engine if the sleeve is not flat or higher than the crankcase

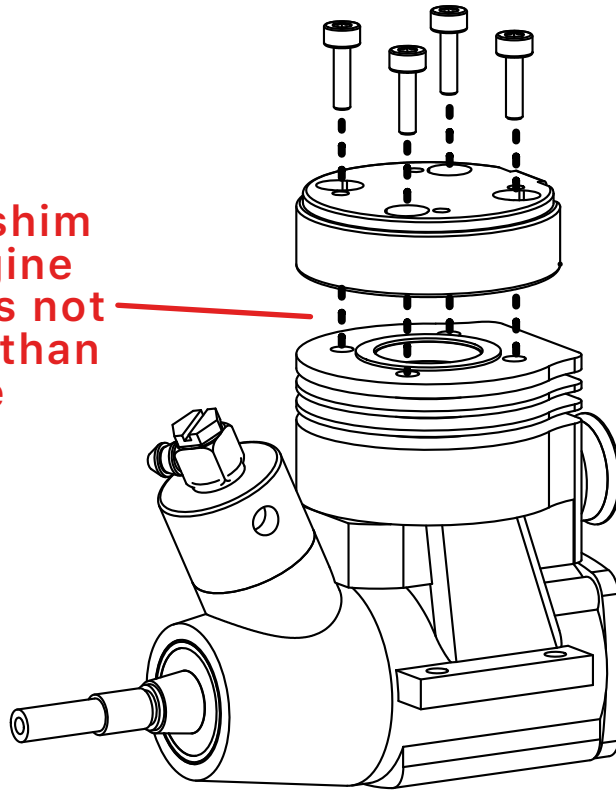

- Tightening the screws with average torque

4

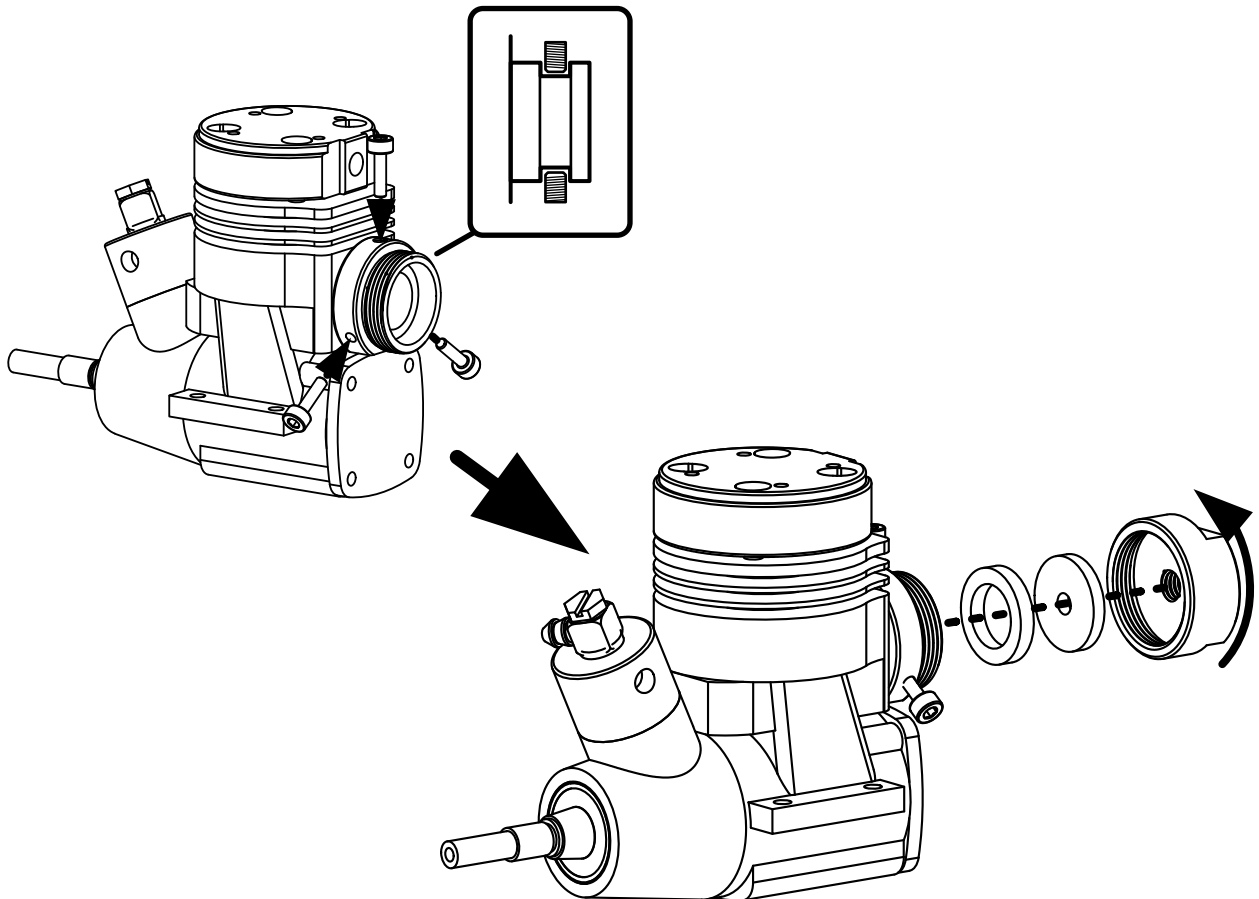

5

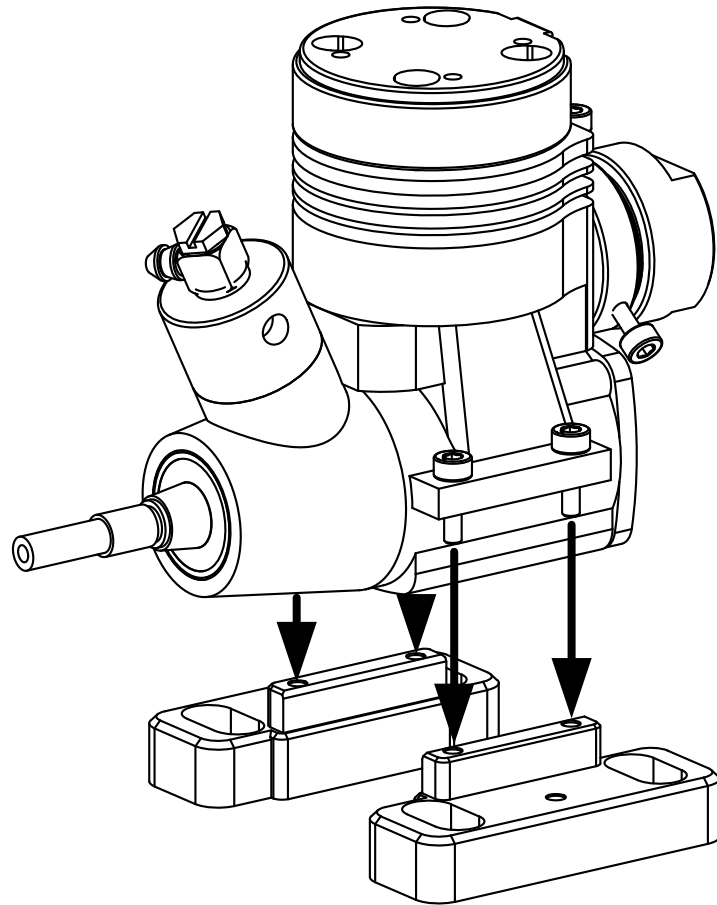

6

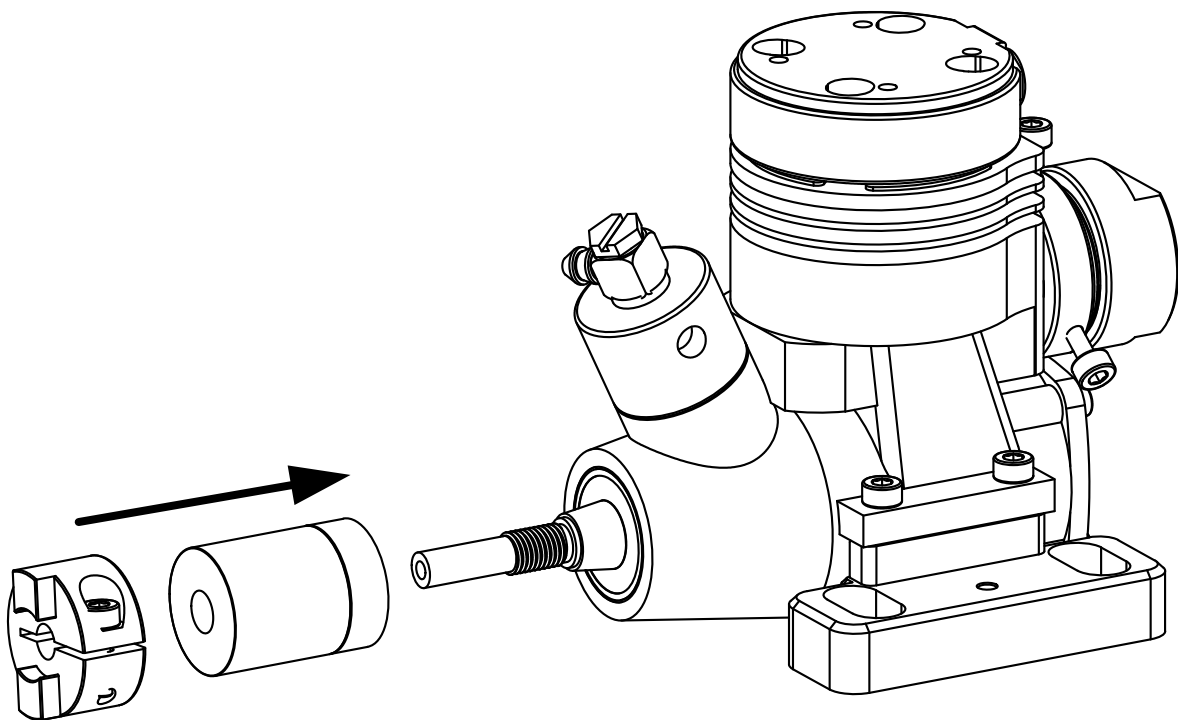

- Please dont tighten the shaft coupling

7

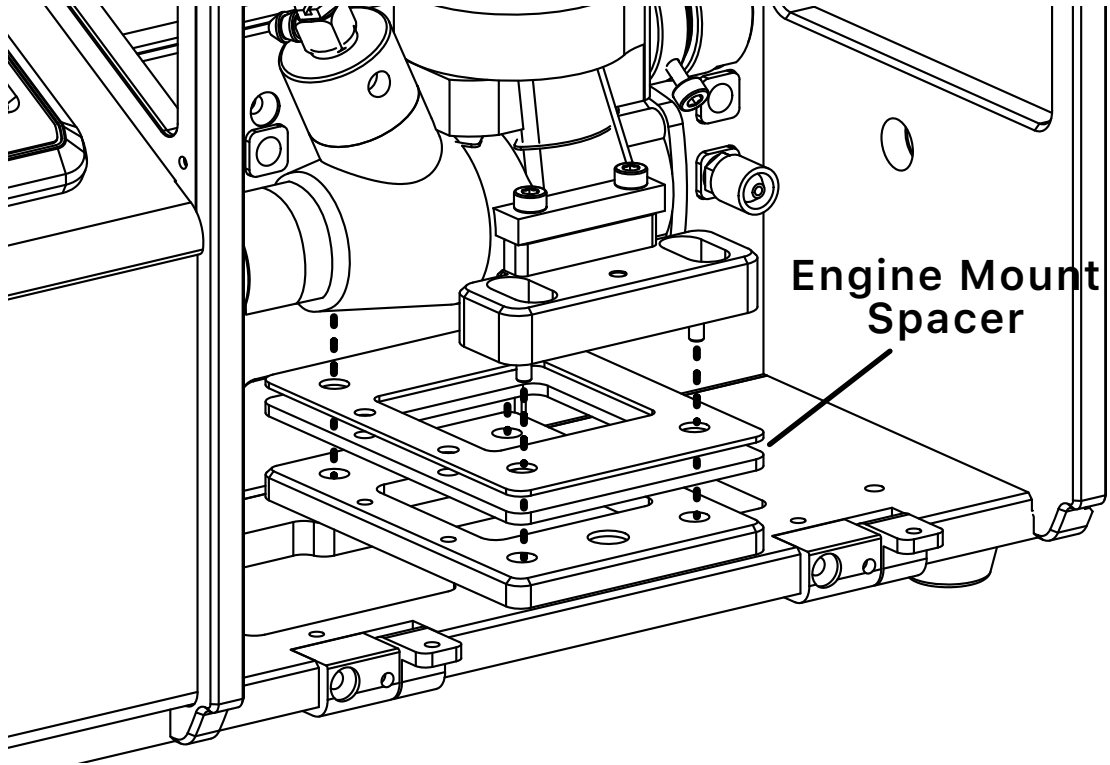

8

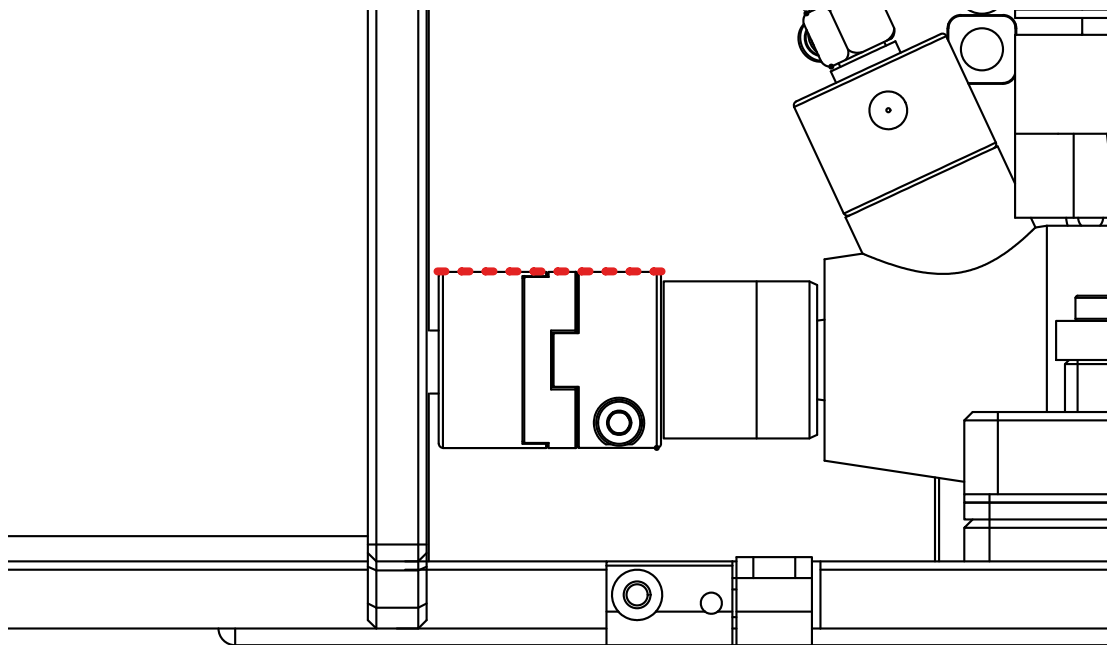

- Using engine mount spacer to adjust the shaft coupling height  
(For different brand engine if needed)

9

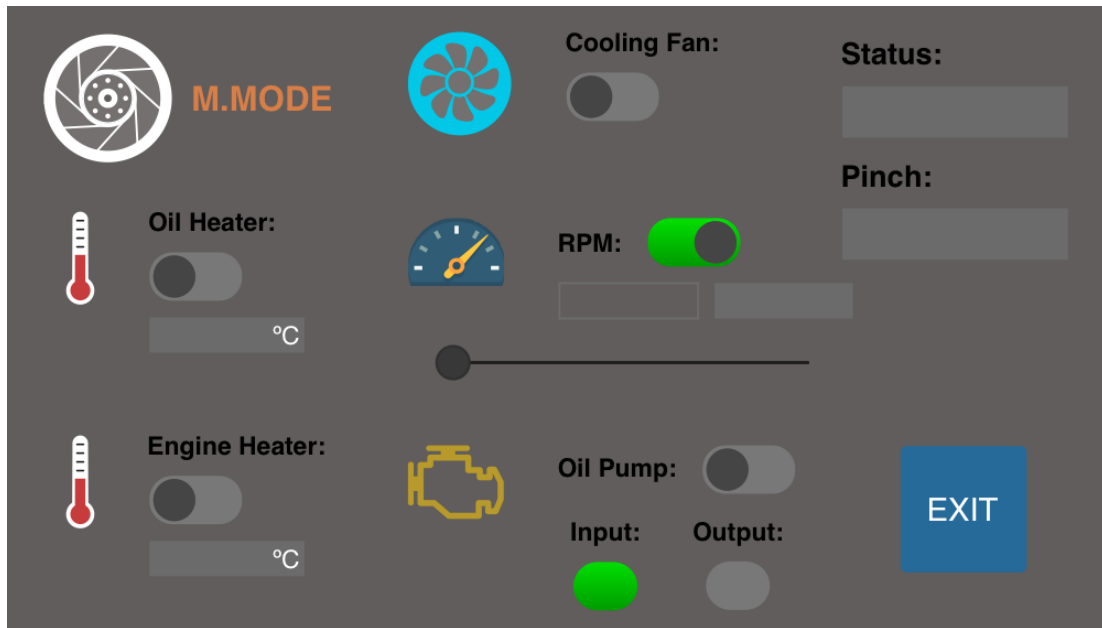

- Turn On the RPM (Motor). The motor will always stop at the same rotation after Turn Off.

10

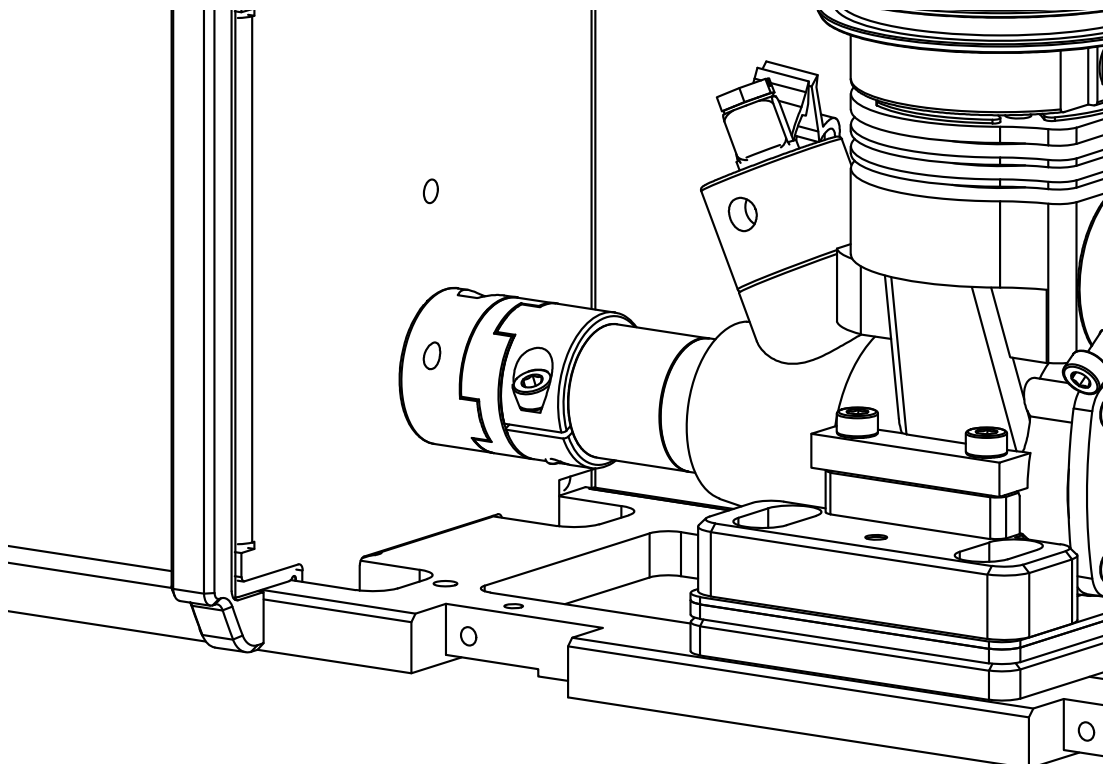

11

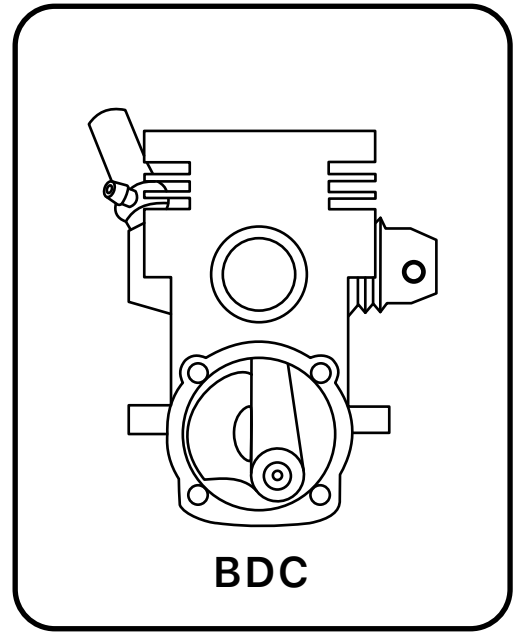
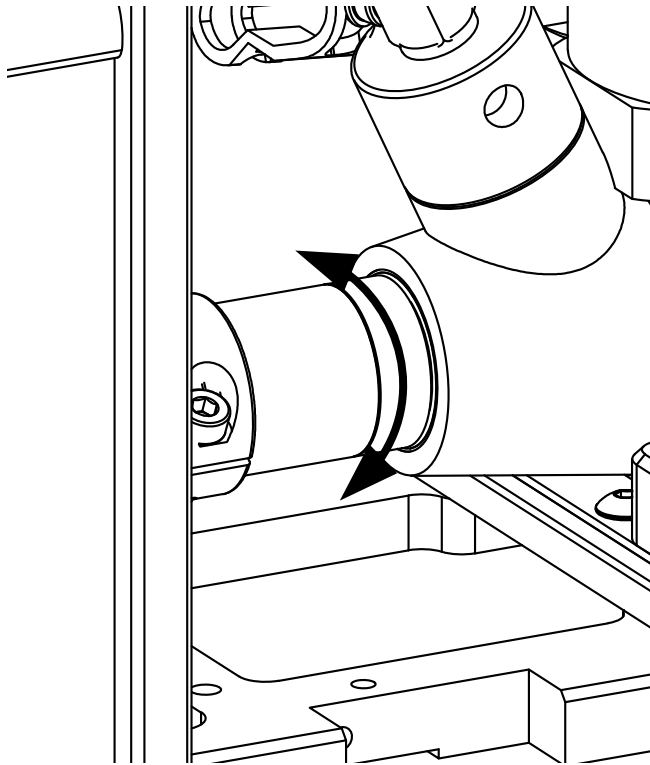

- Rotate engine piston to the BDC(Bottom Death Center)

---

12

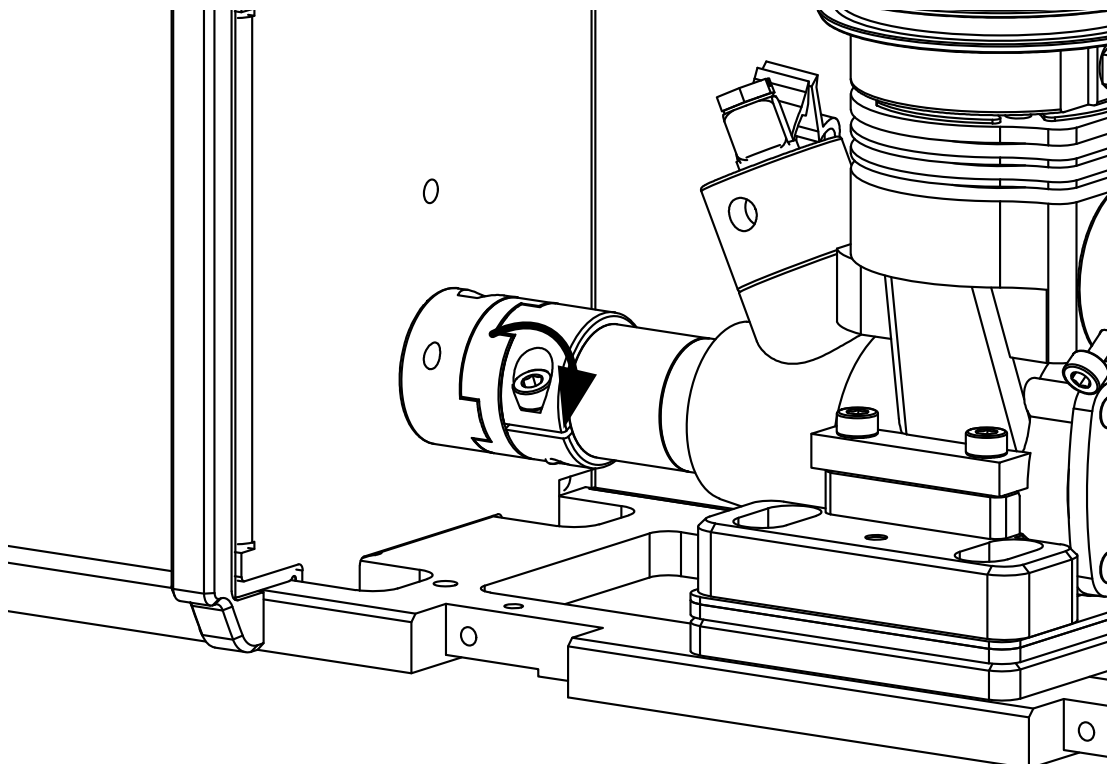

13

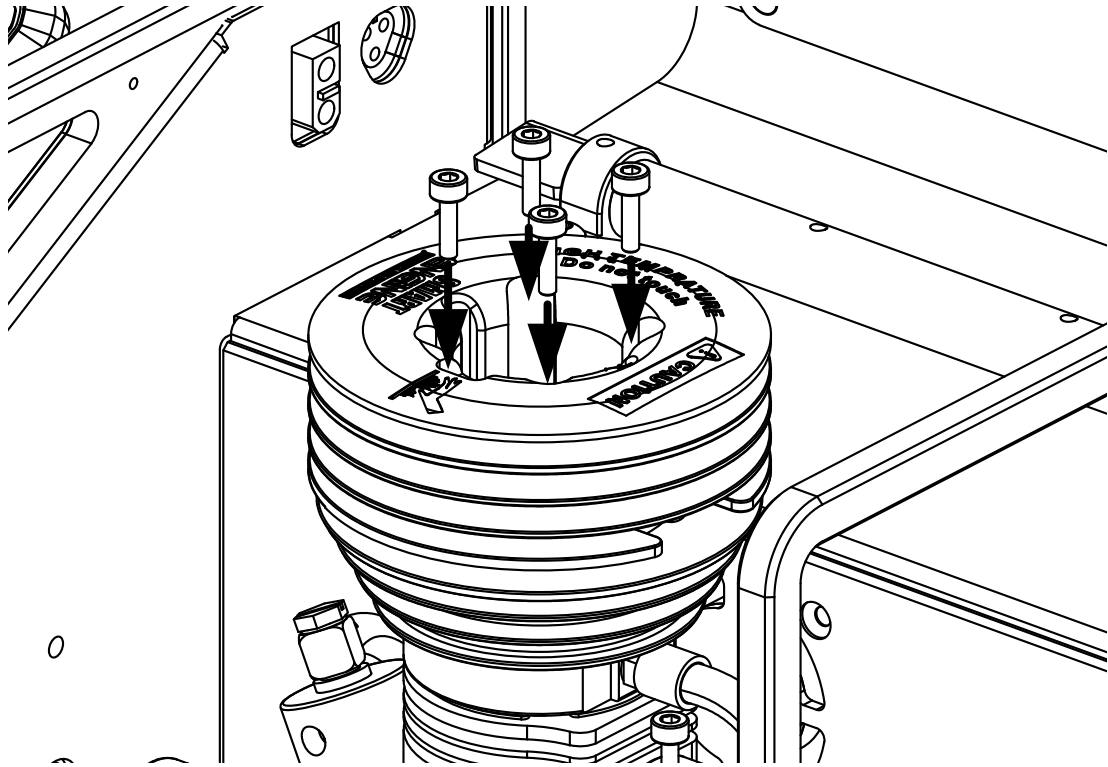

14

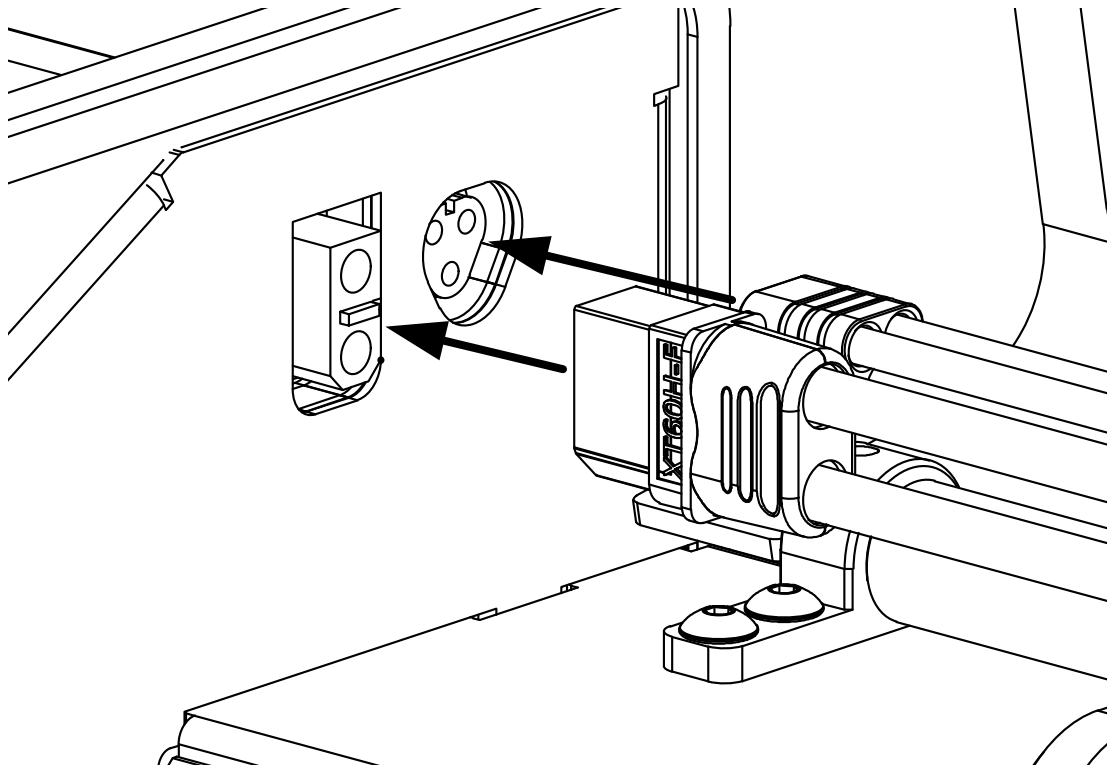



15

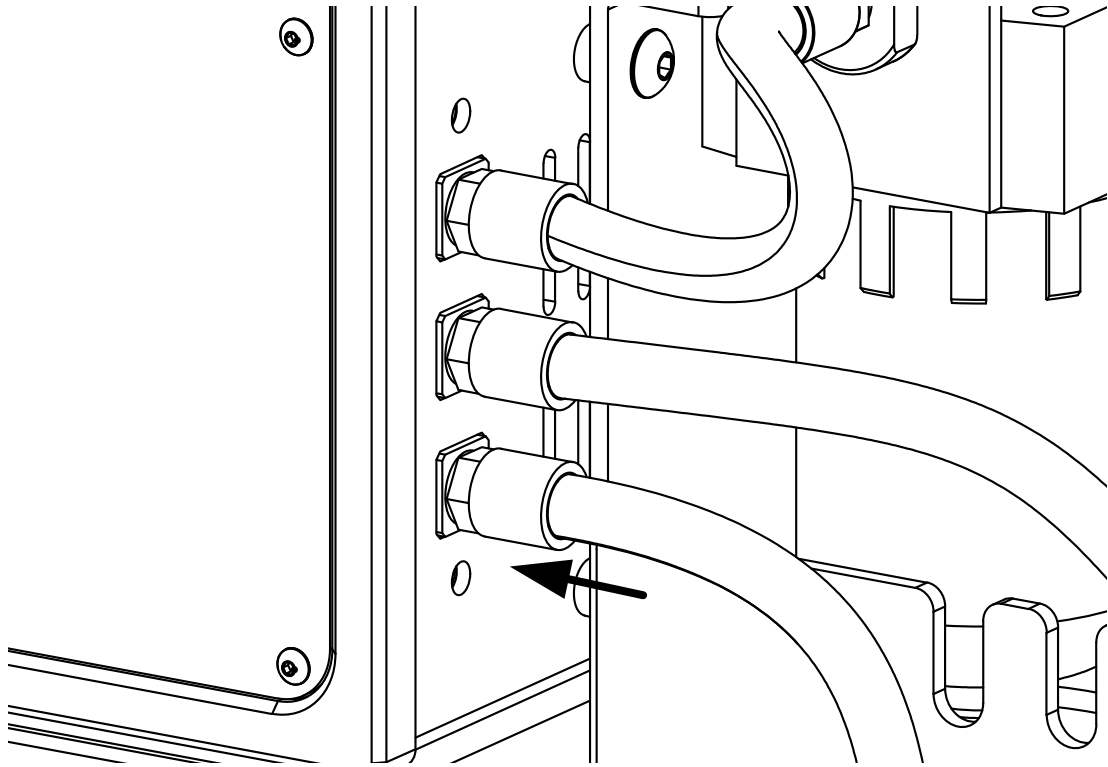

16

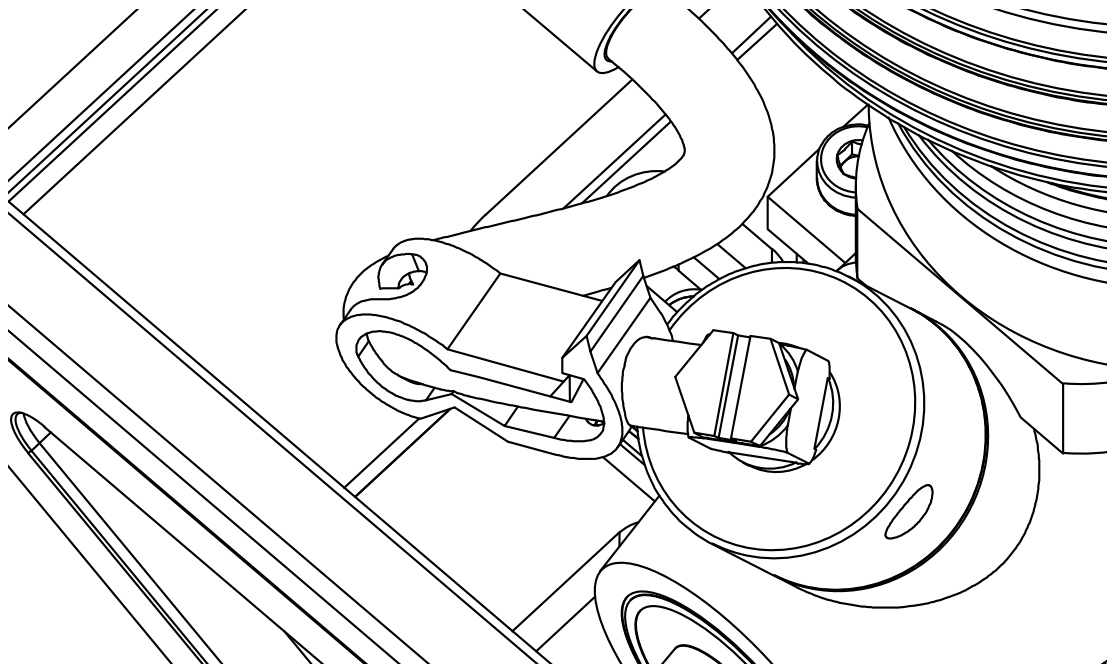

\* Clip the fuel line clip on the inlet fuel line

# 17

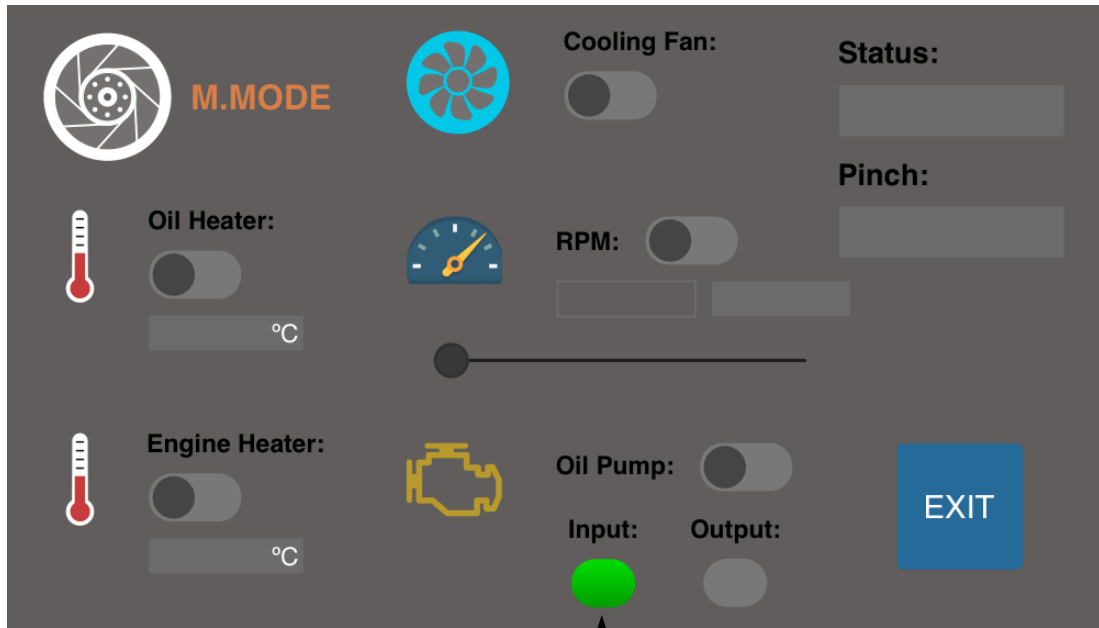

Home > Manual Mode

# 18

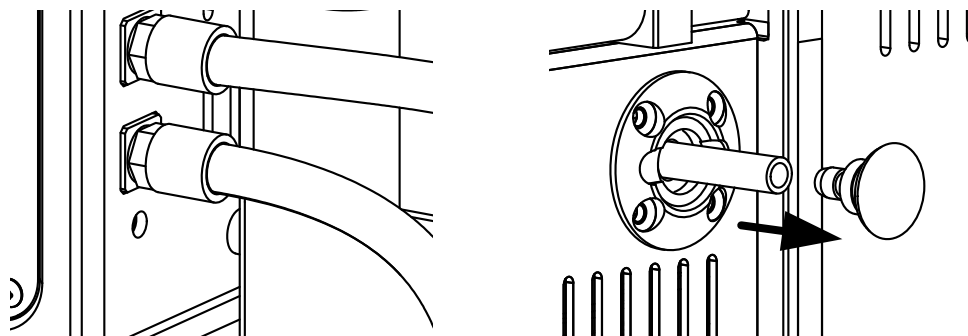
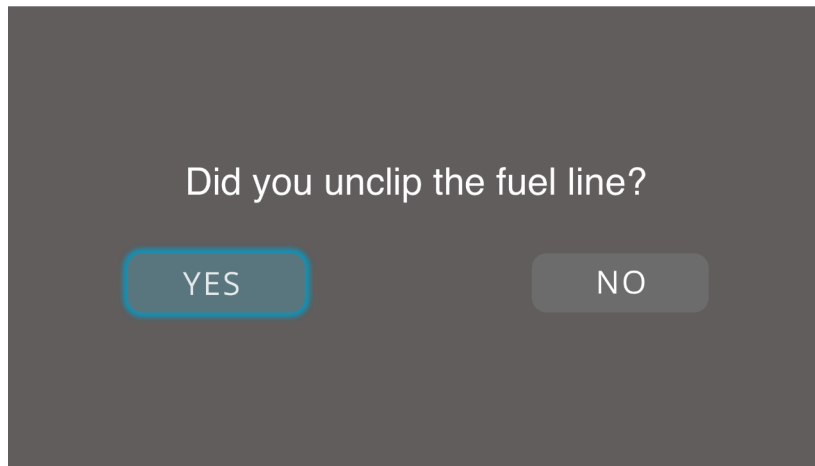

- Ensure the Pump In/Out fuel line is unblocked

# 19

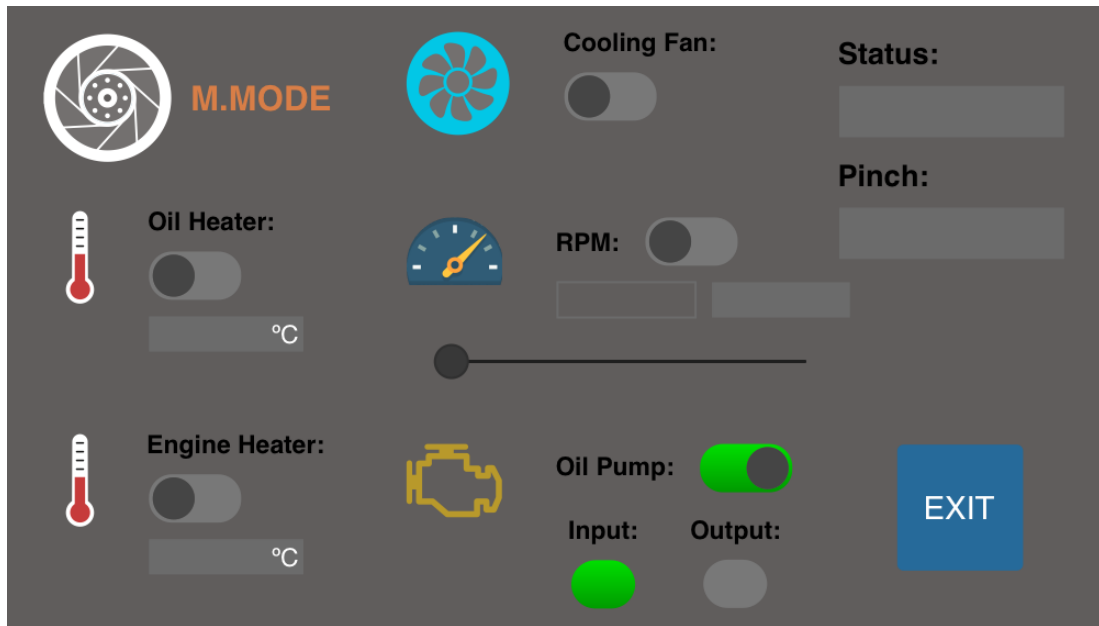

- The oil will start pump in to the oil tank

# 20

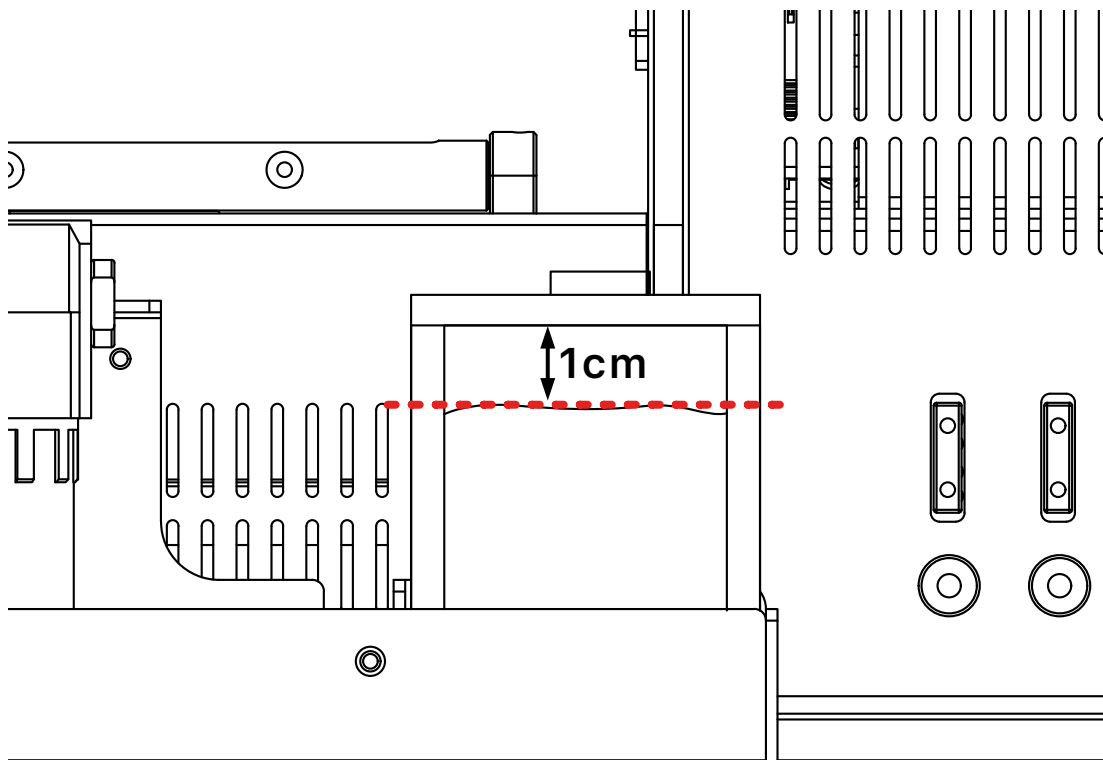

- Maximum oil level

# 21

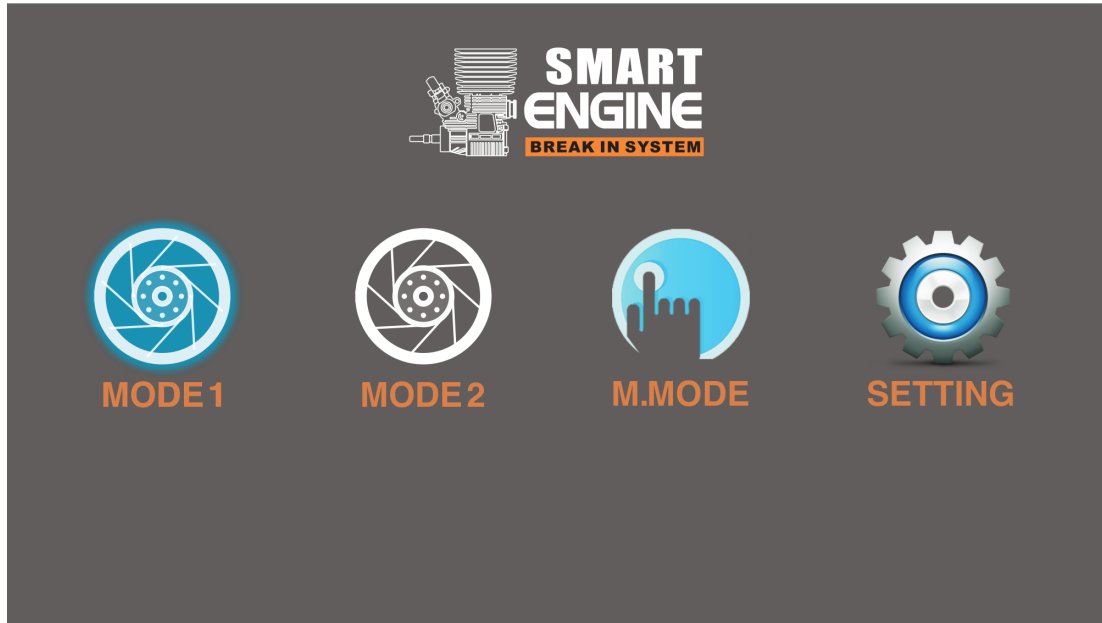

- Home > Mode 1

# 22

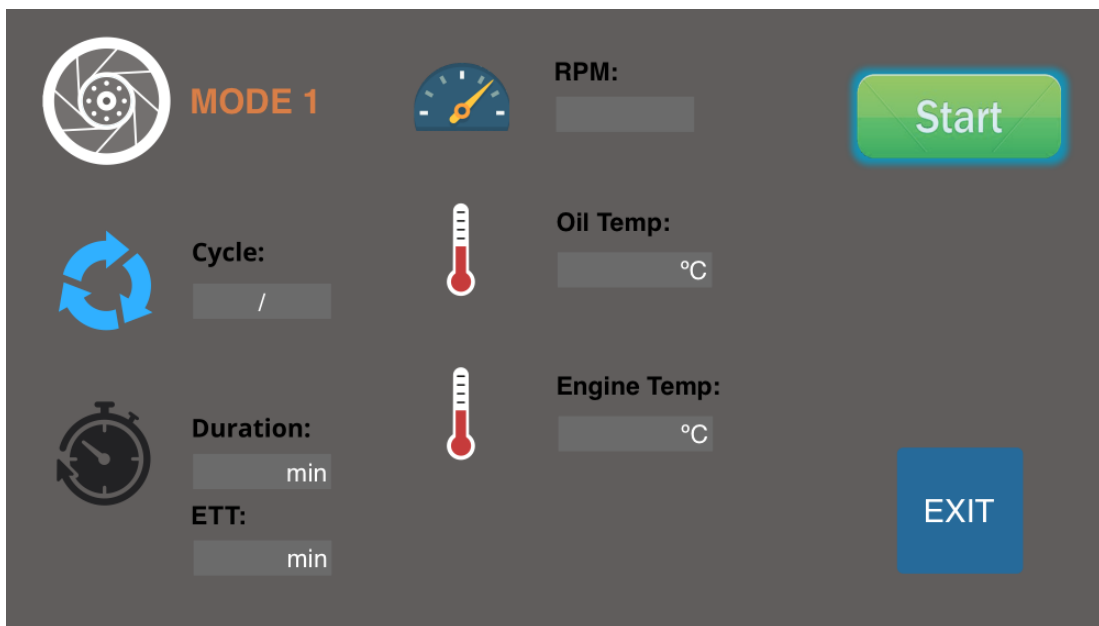

- Ensure all the parameter is correct before start operating

# 23

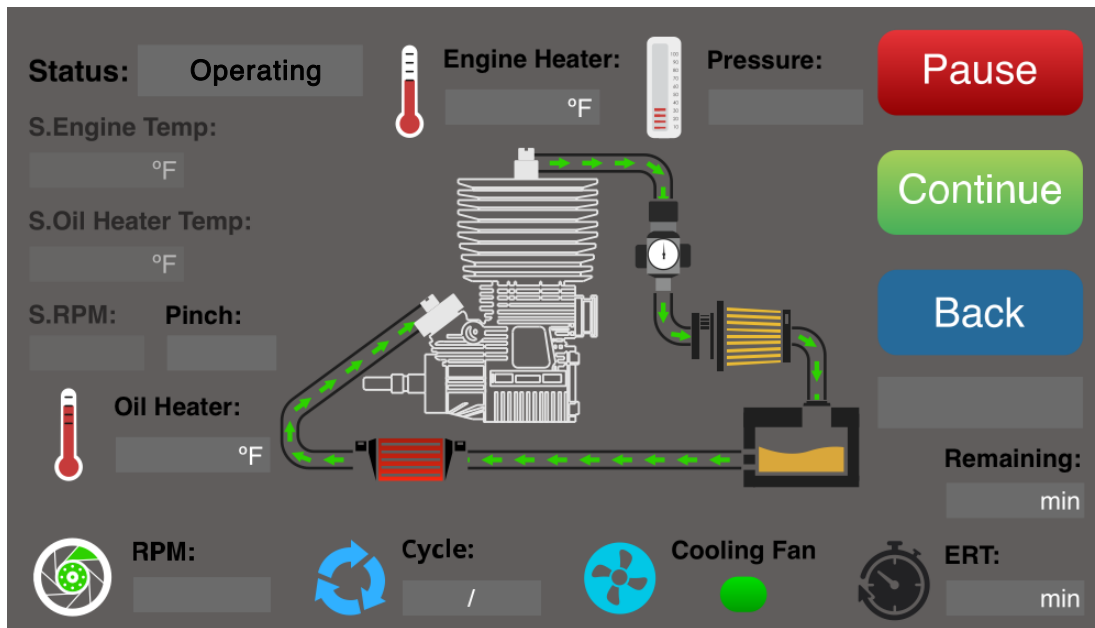

- The system will start operating

# 24

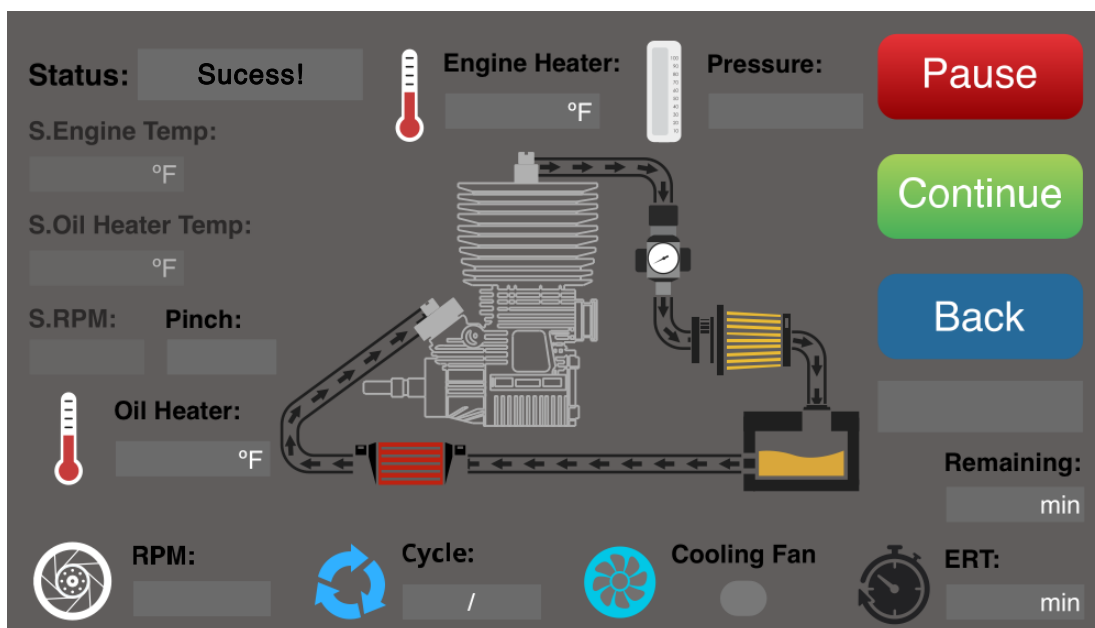

- The Status will show "Sucess" after the operating is done

# Spring Tension Installation

---

1

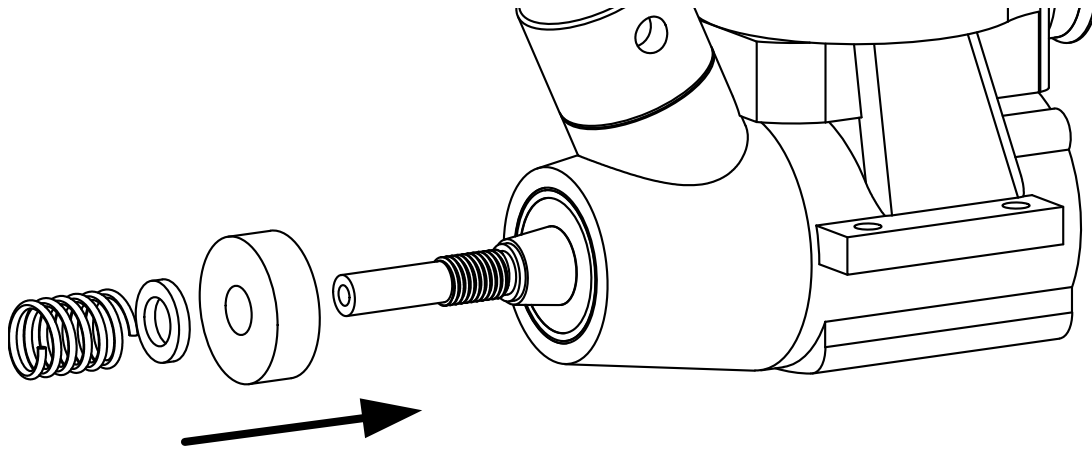

\* This compartment is only needed for the engine using old bearing to prevent oil leaking during the operation.

---

2

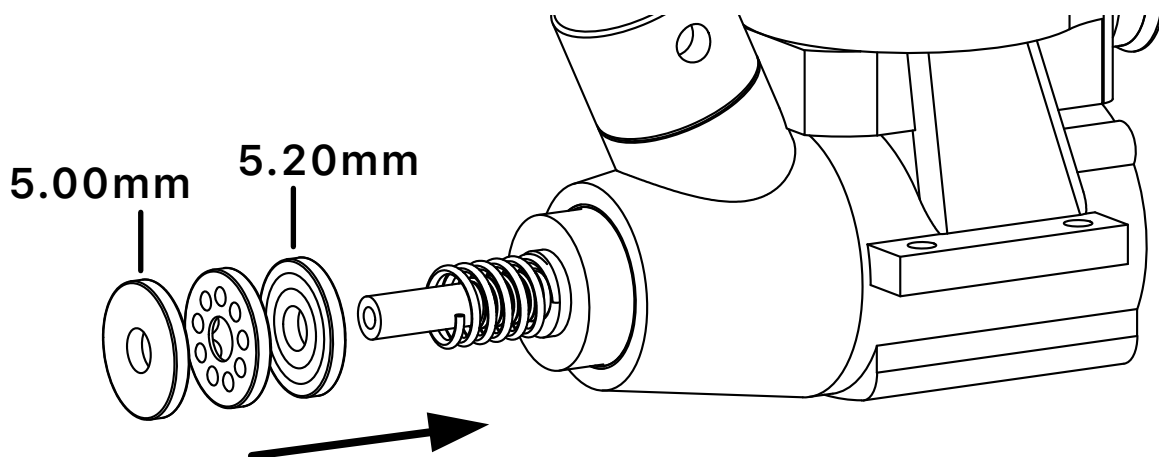

3

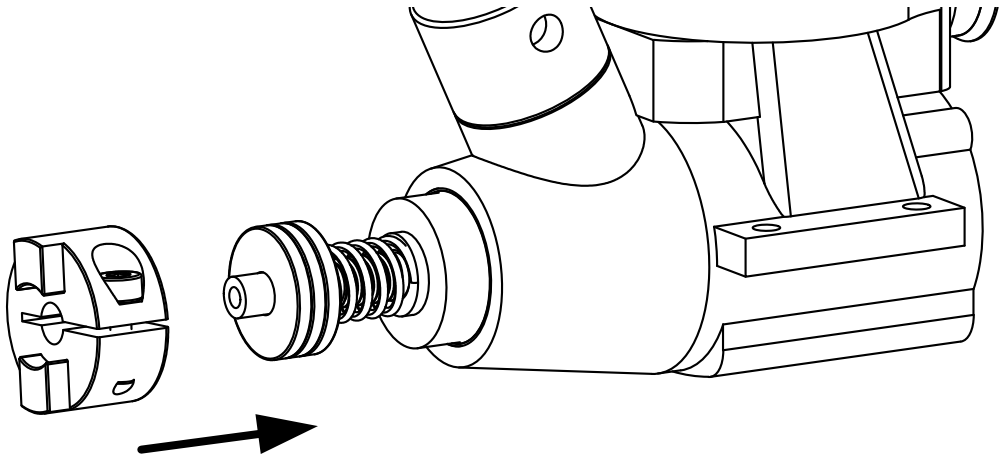

---

4

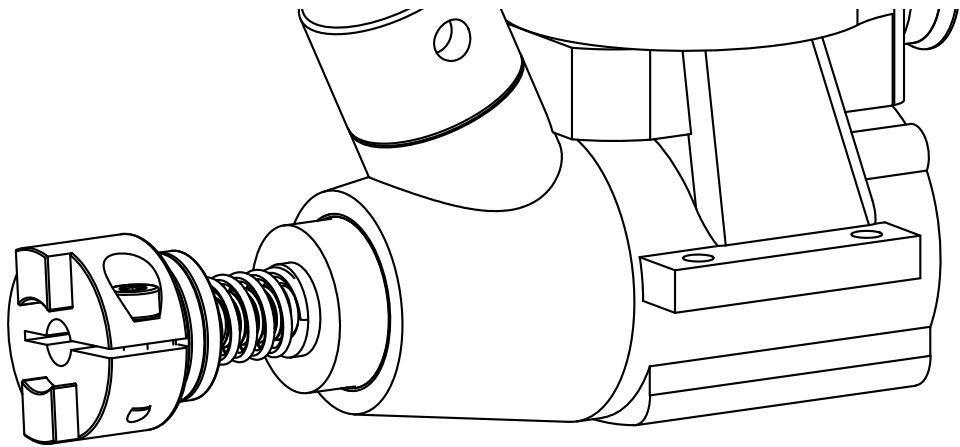

# Start With Oil Bath

---

1

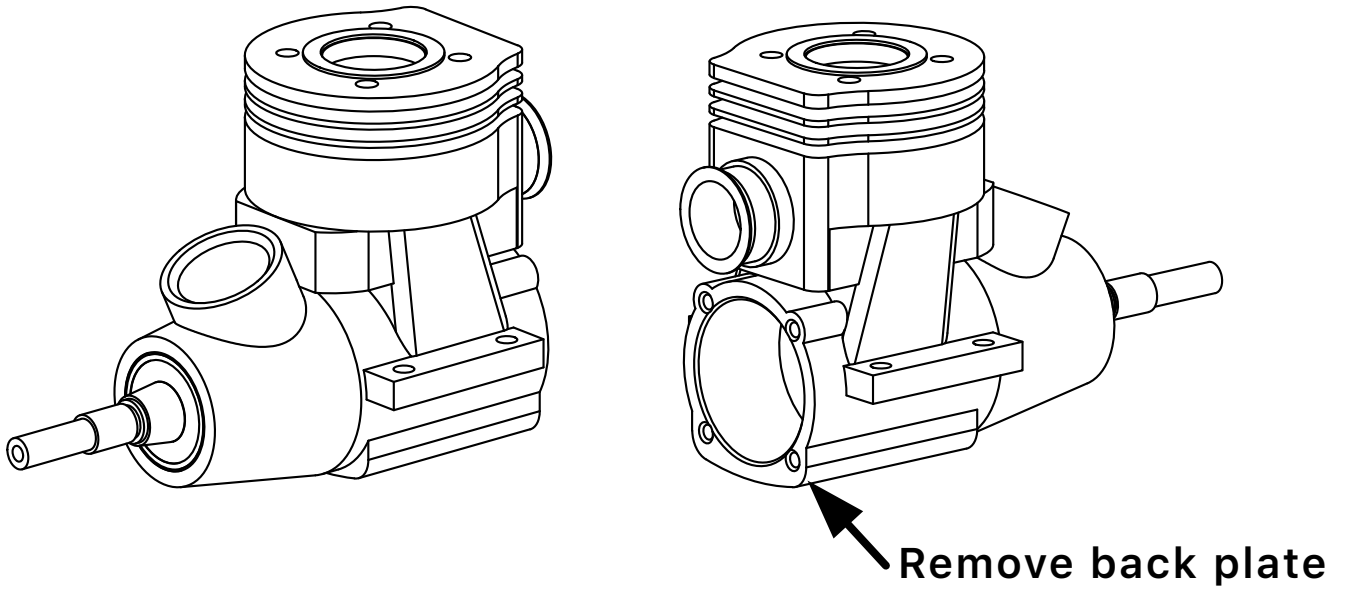

2

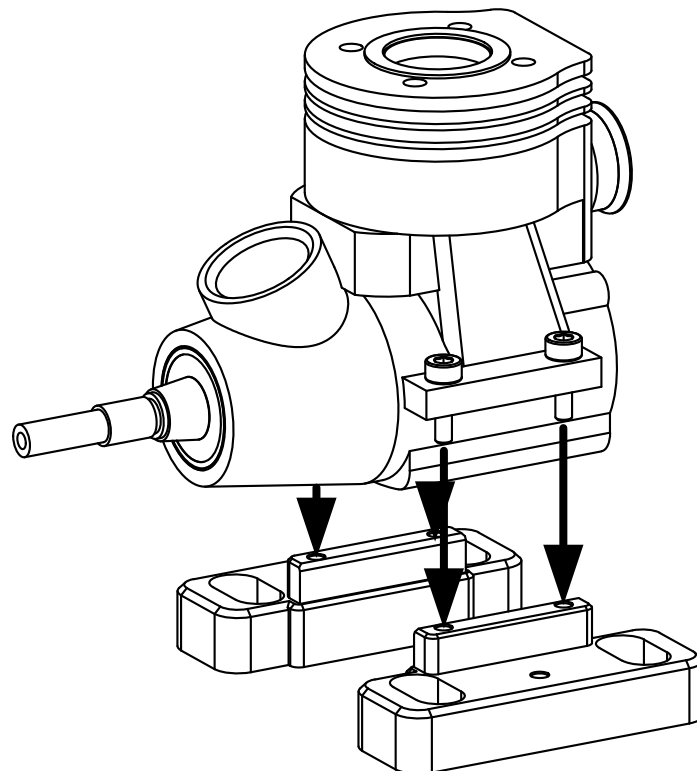



3

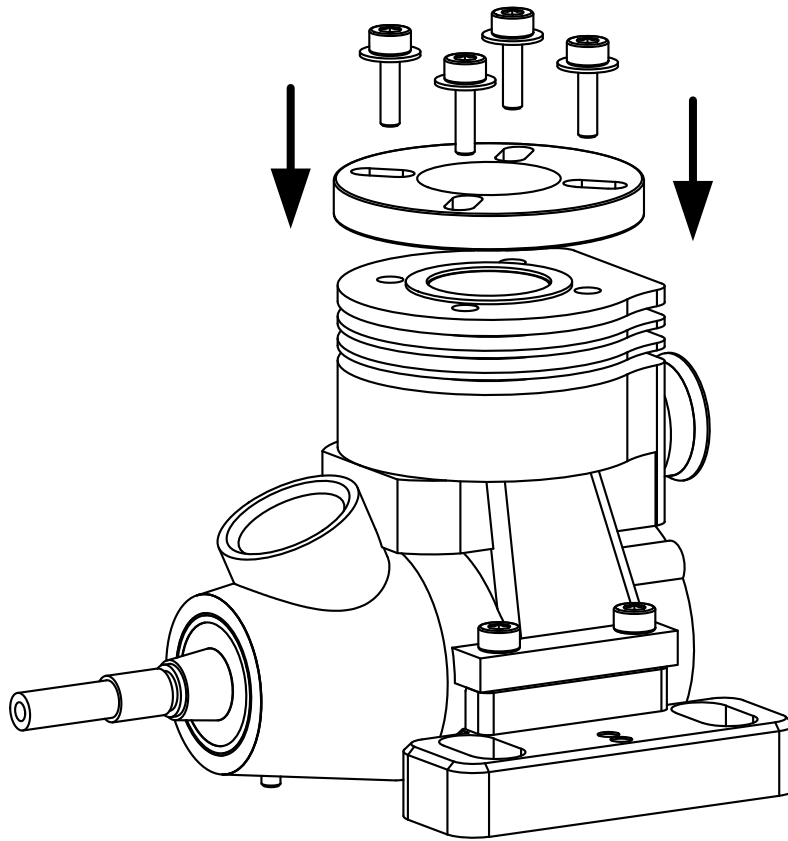

4

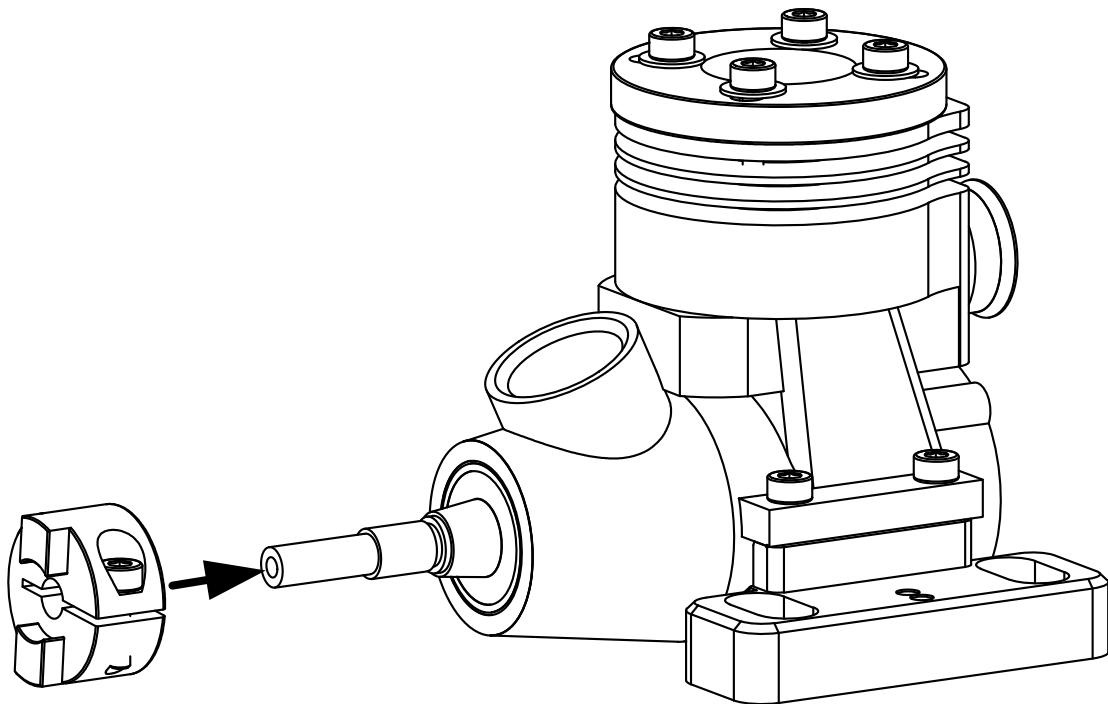

- Please dont tighten the shaft coupling first

5

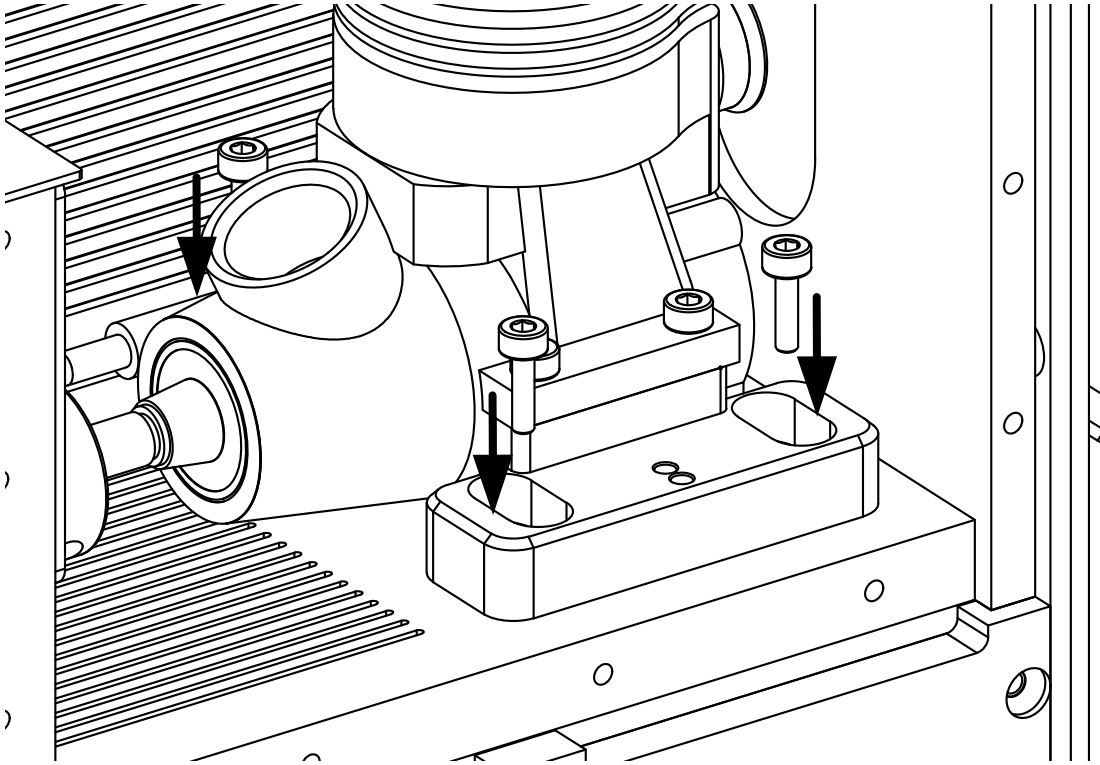

6

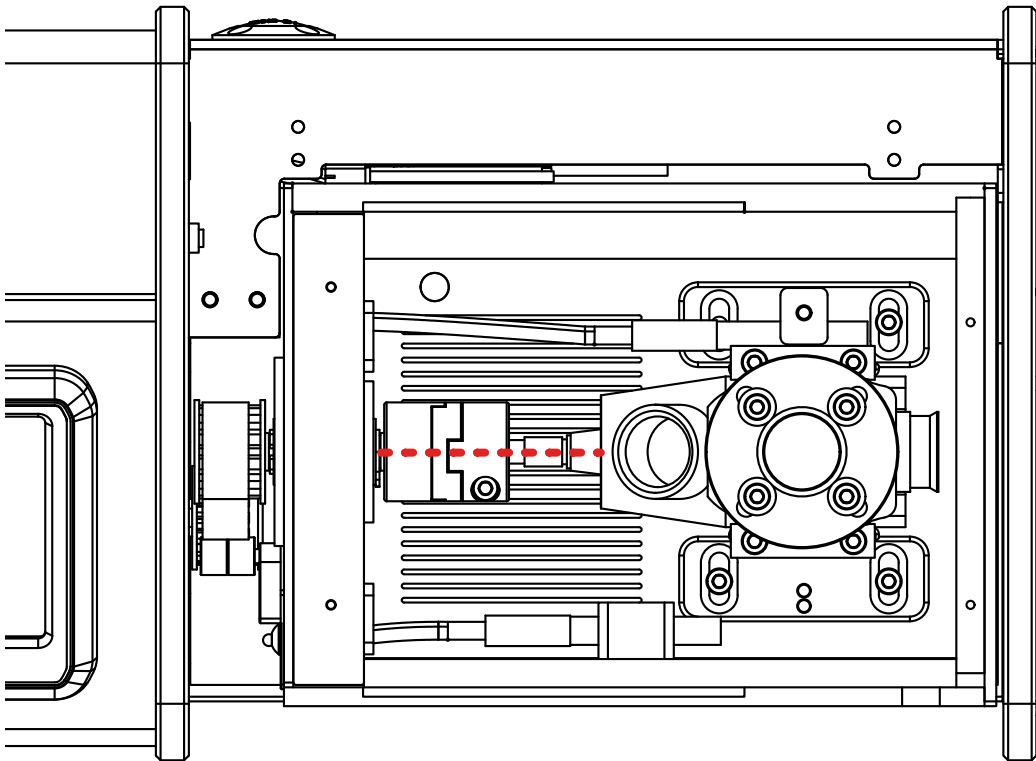

7

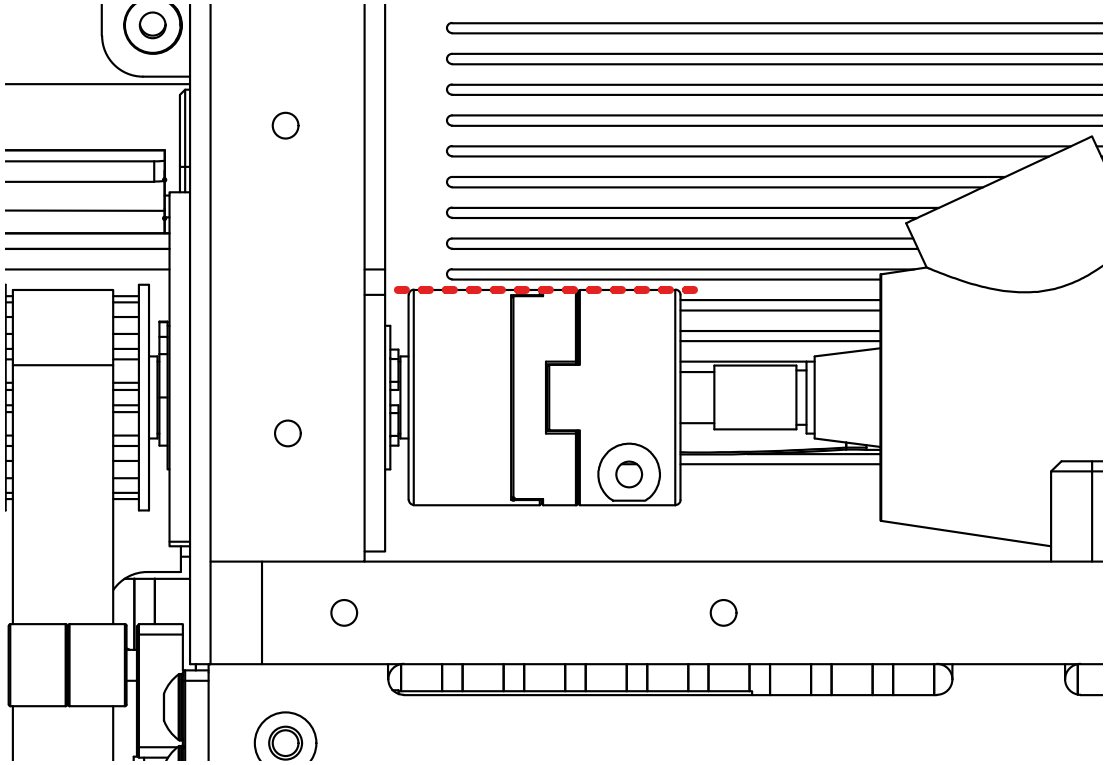

8

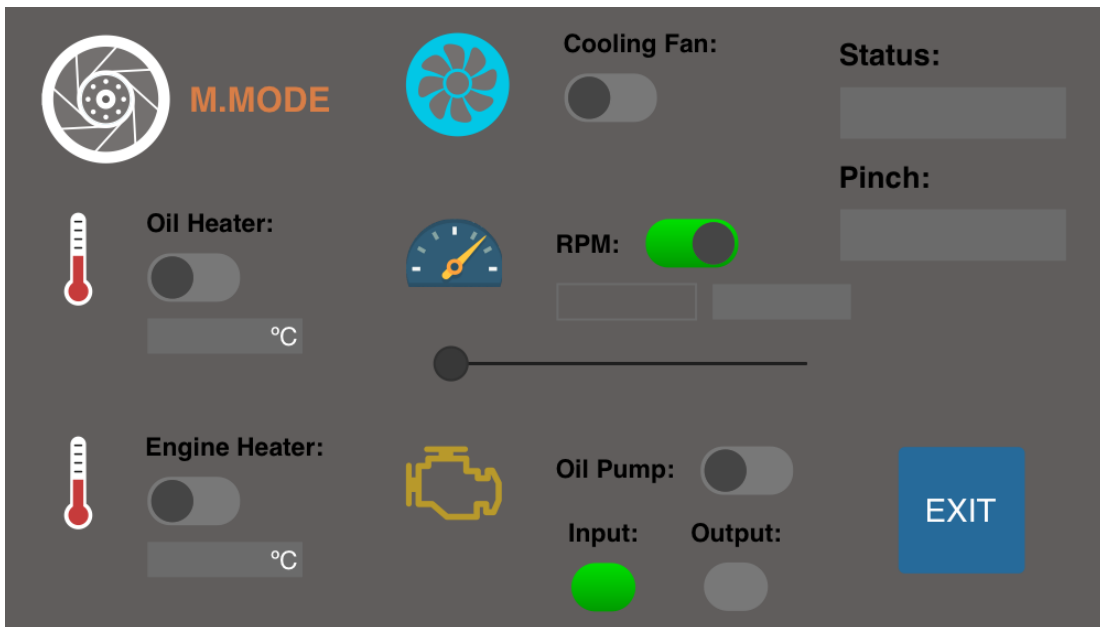

- Turn On the RPM (Motor). The motor will always stop at the same rotation after Turn Off.

9

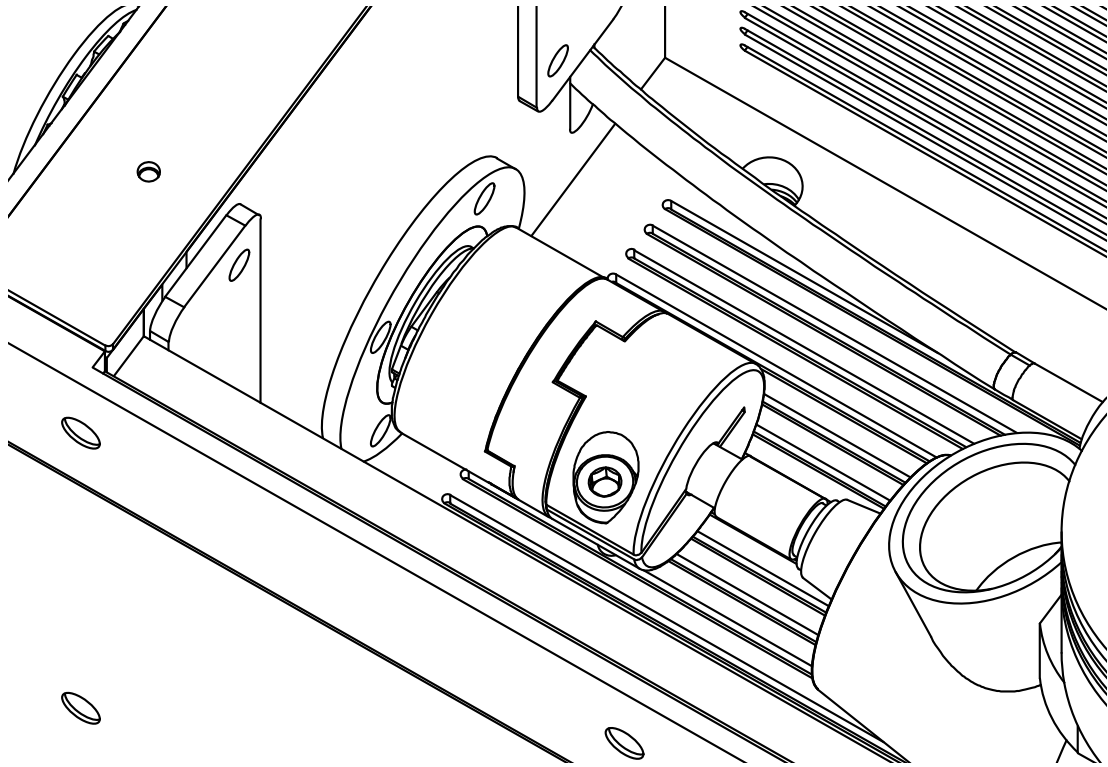

10

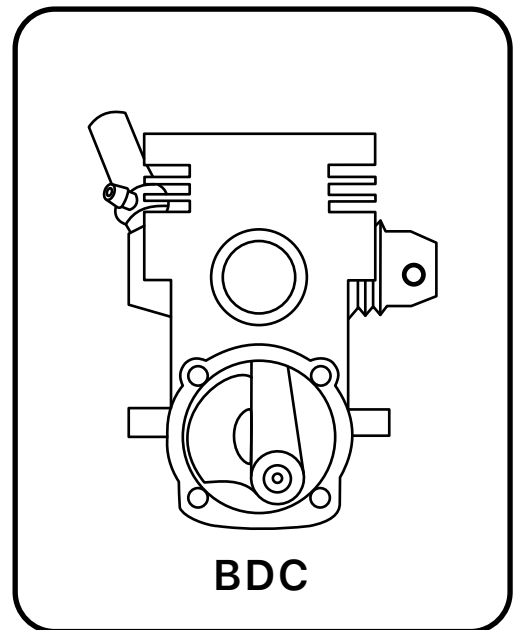
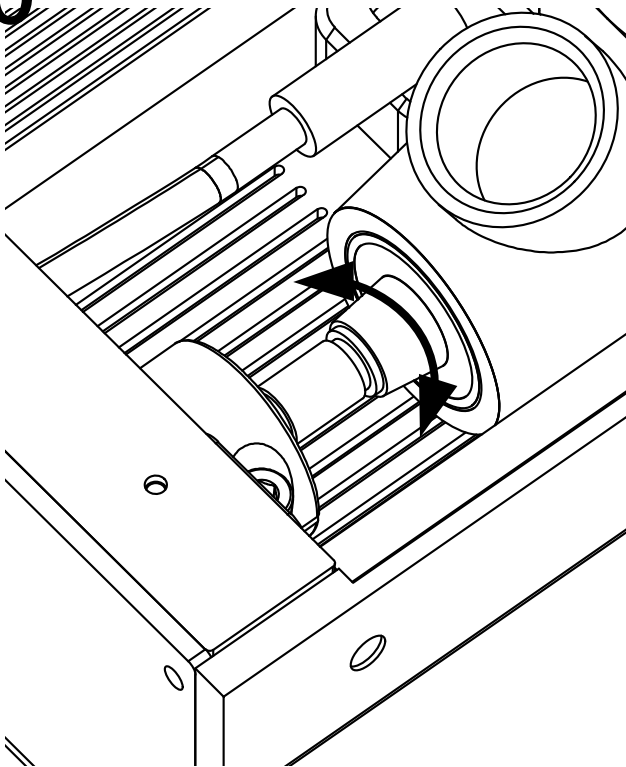

- Rotate engine piston to the BDC (Bottom Death Center)

11

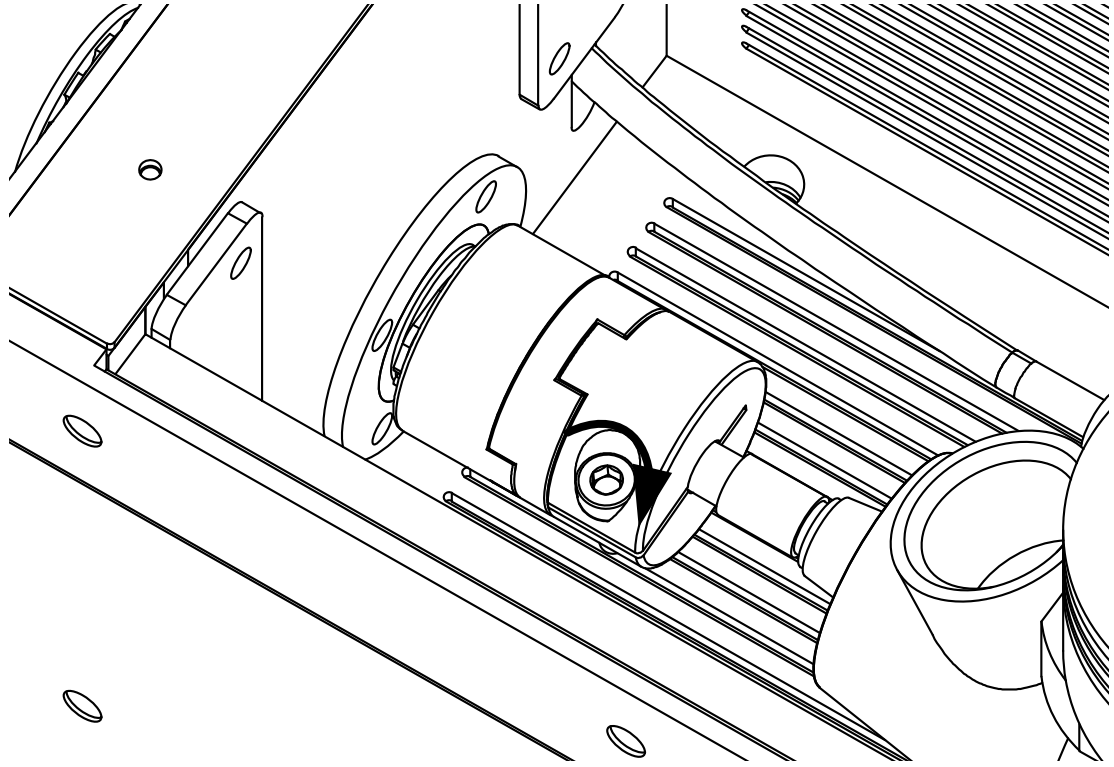

12

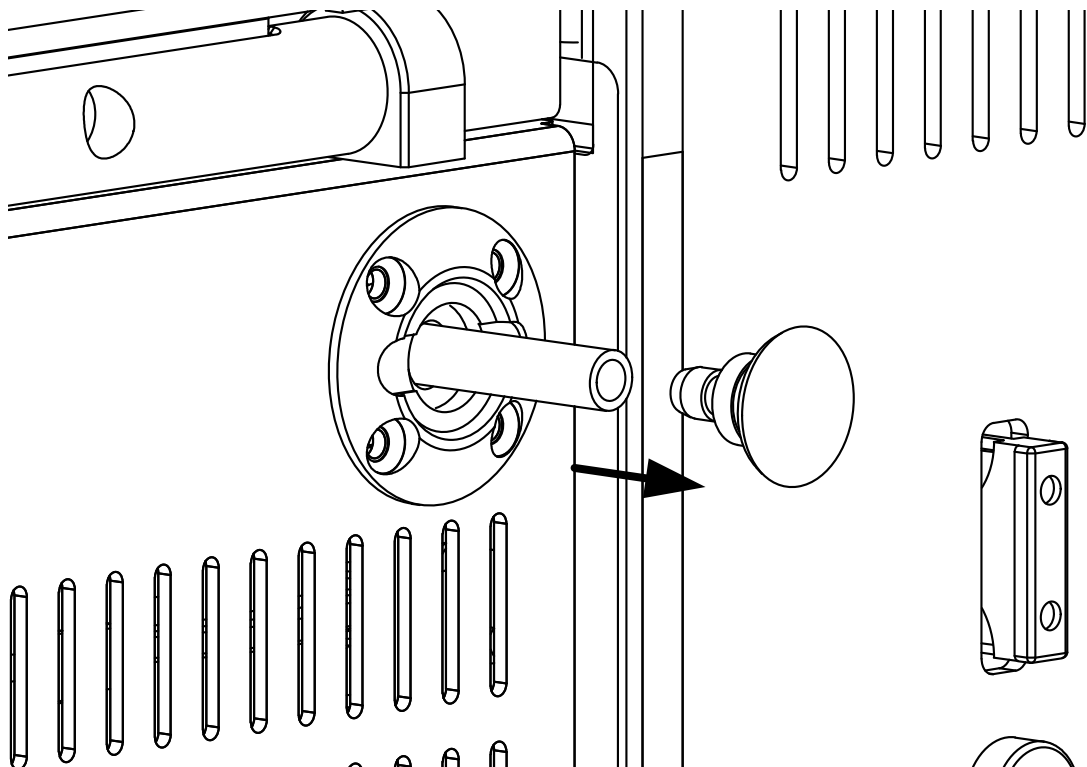

# 13

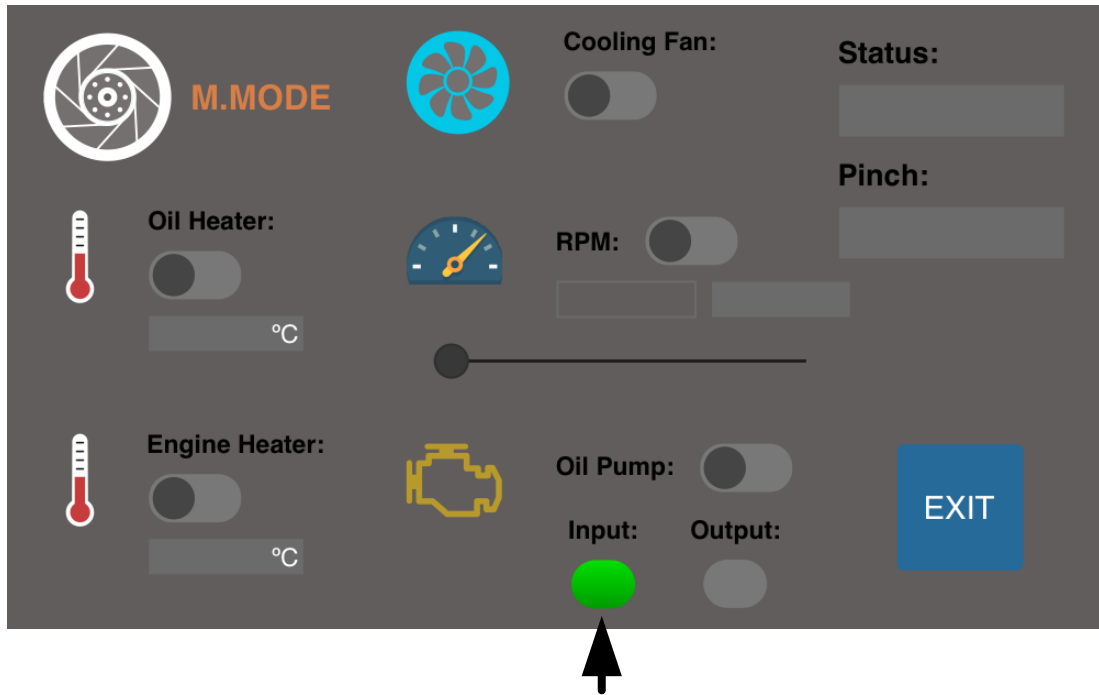

# 14

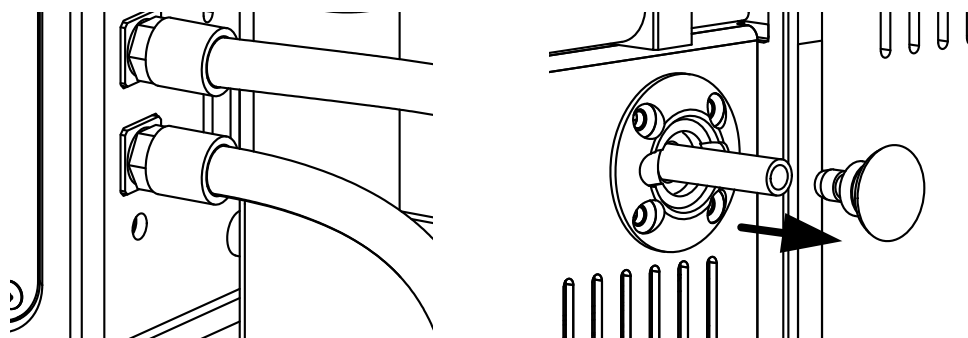
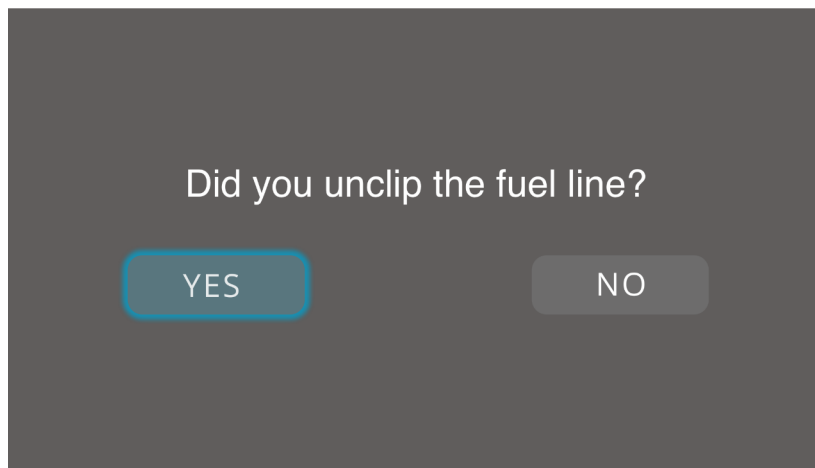

- Ensure the Pump In/Out fuel line is unblocked

# 15

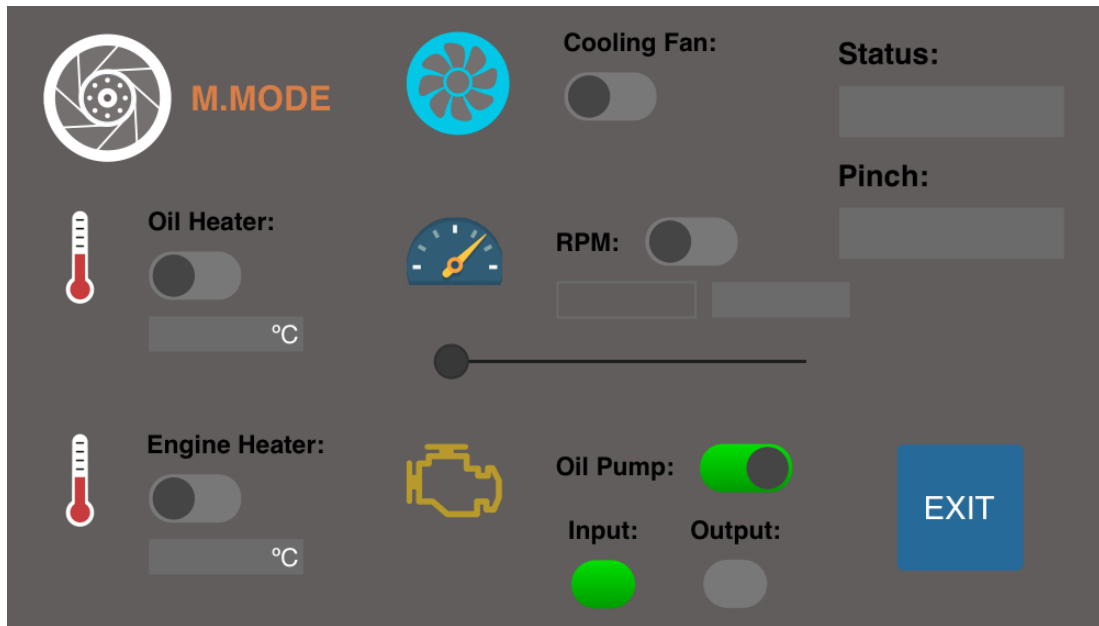

- The oil will start pump in to the oil tank

# 16

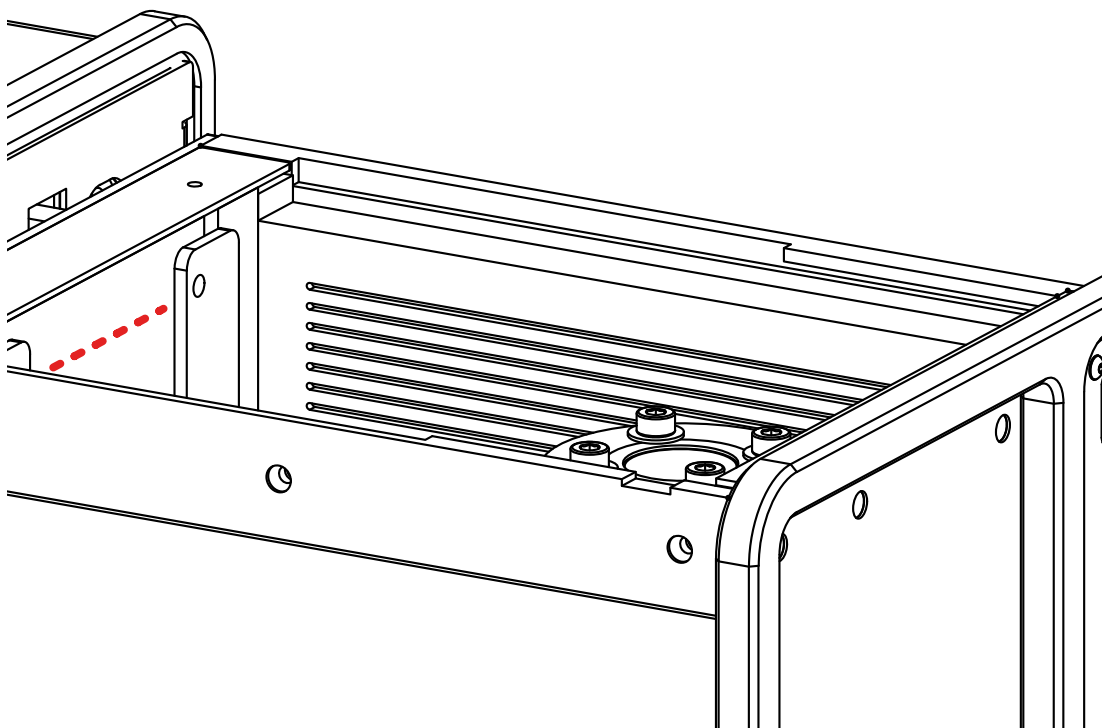

- Do not exit the maximum oil level

17

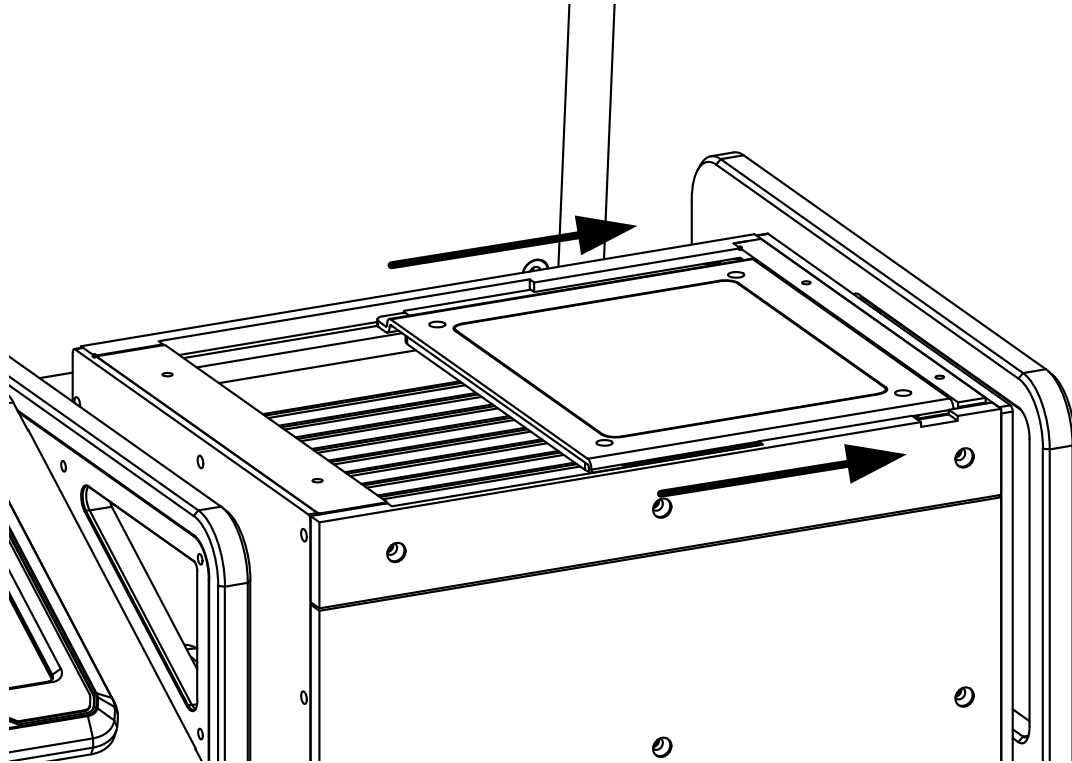

18

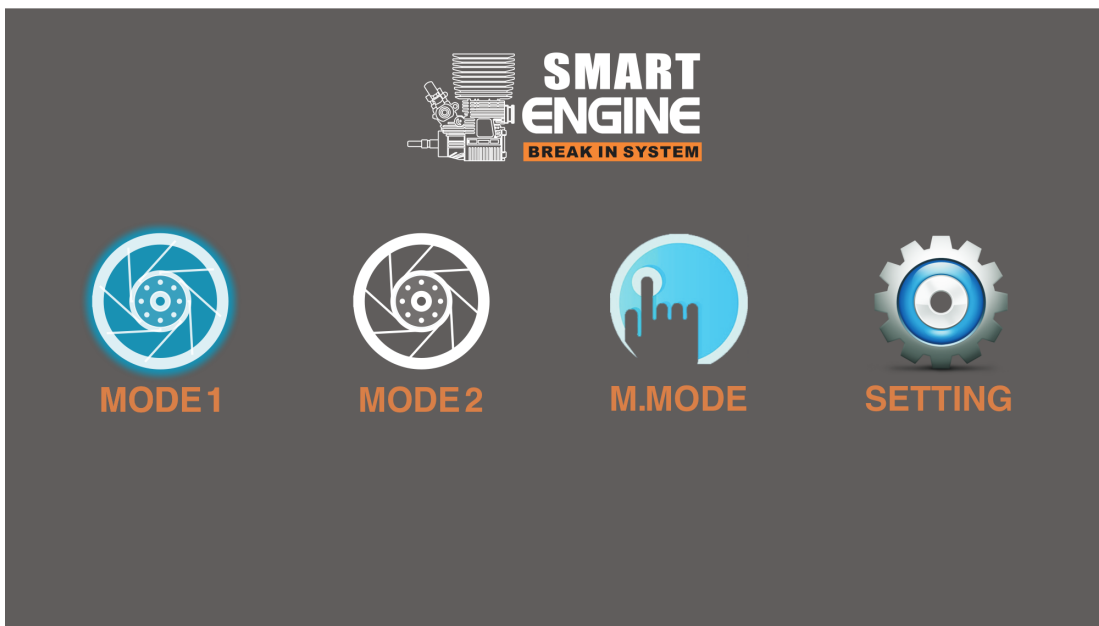

- Home > Mode 1



# 19

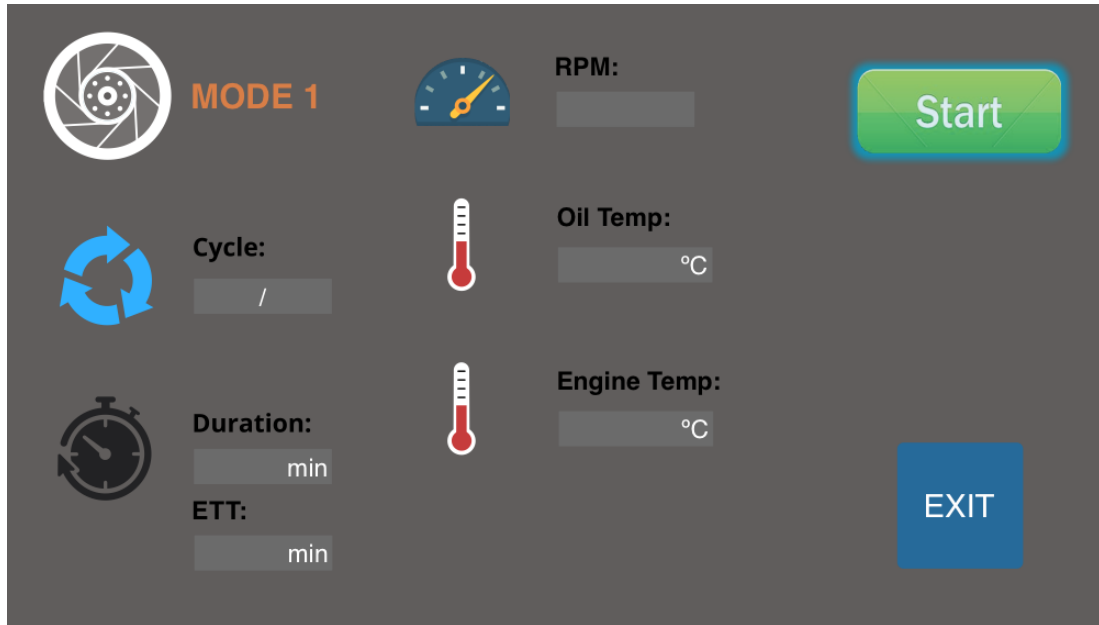

- Ensure all the parameter is correct before start operating

# 20

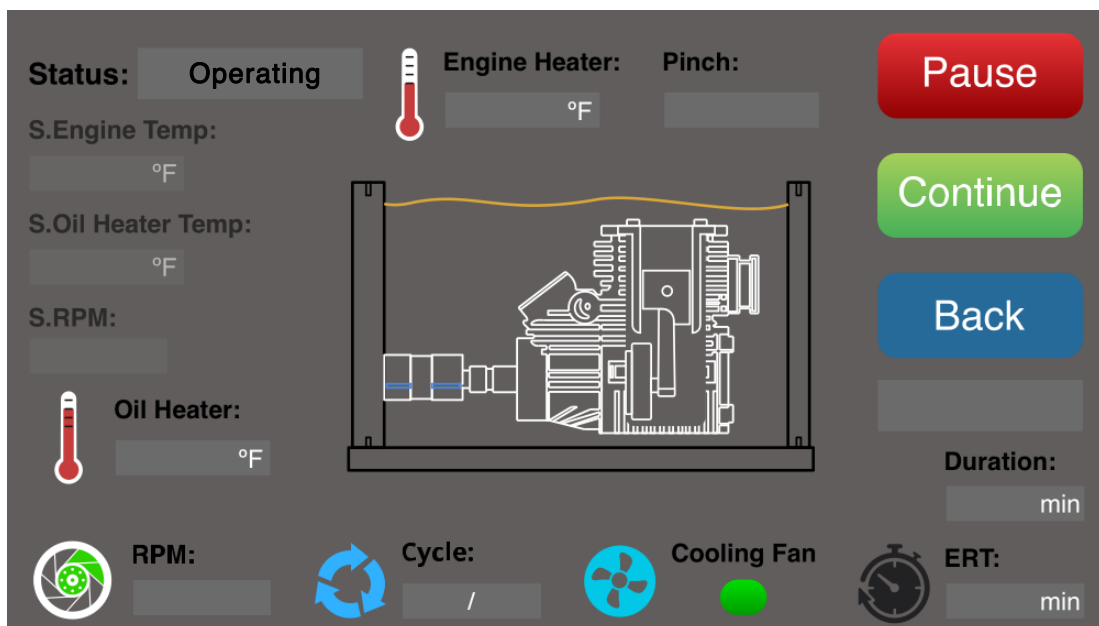

- The system will start operating

21

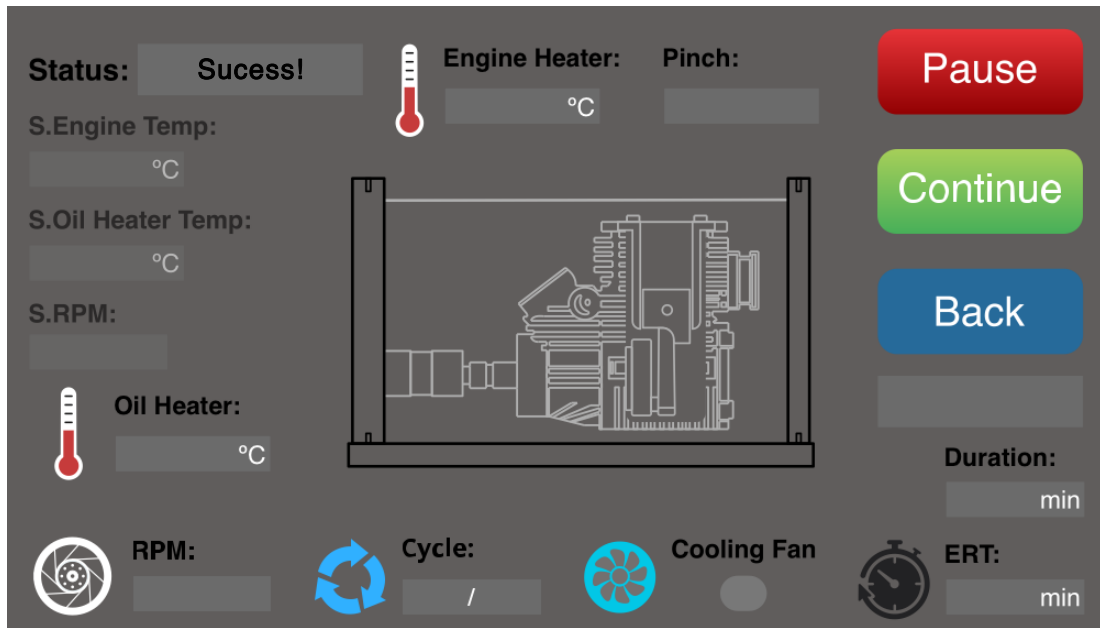

- The Status will show "Sucess" after the operating is done

# Withdraw Oil

---

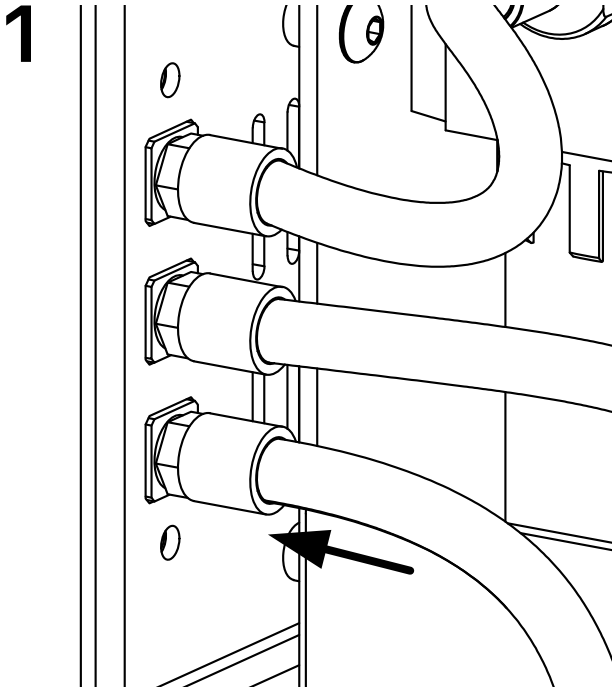

Oil Running

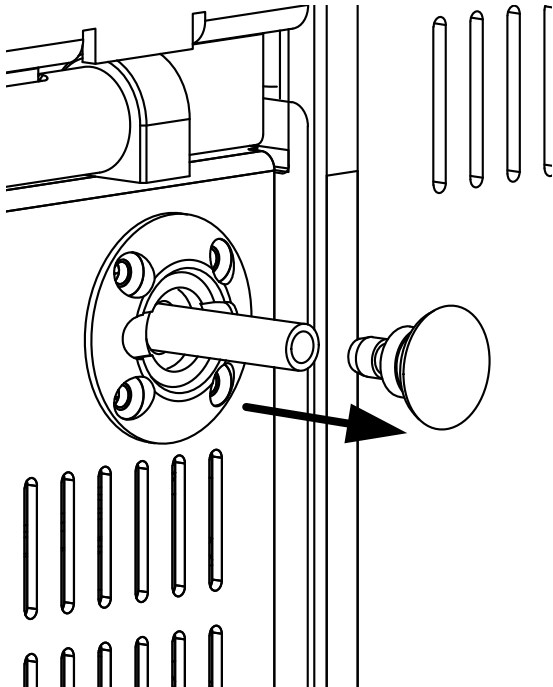

Oil Bath

---

## 2

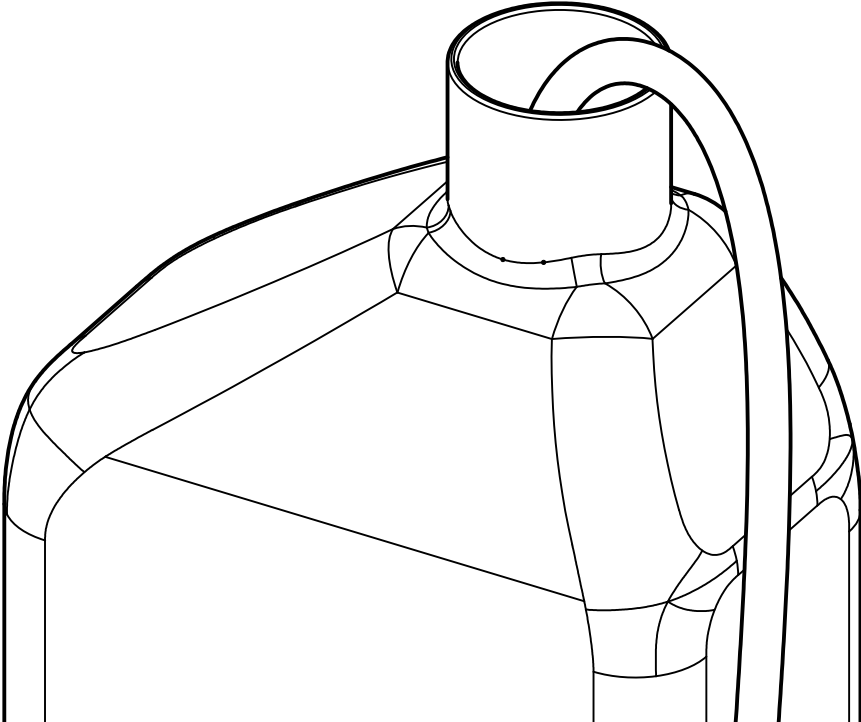

3

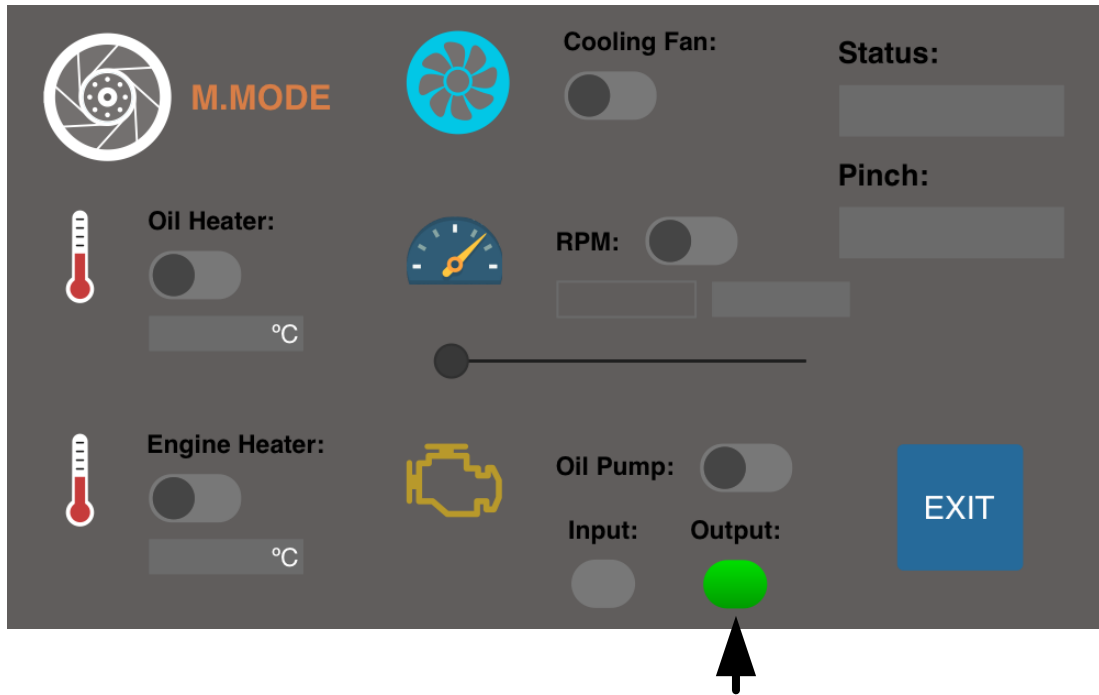

4

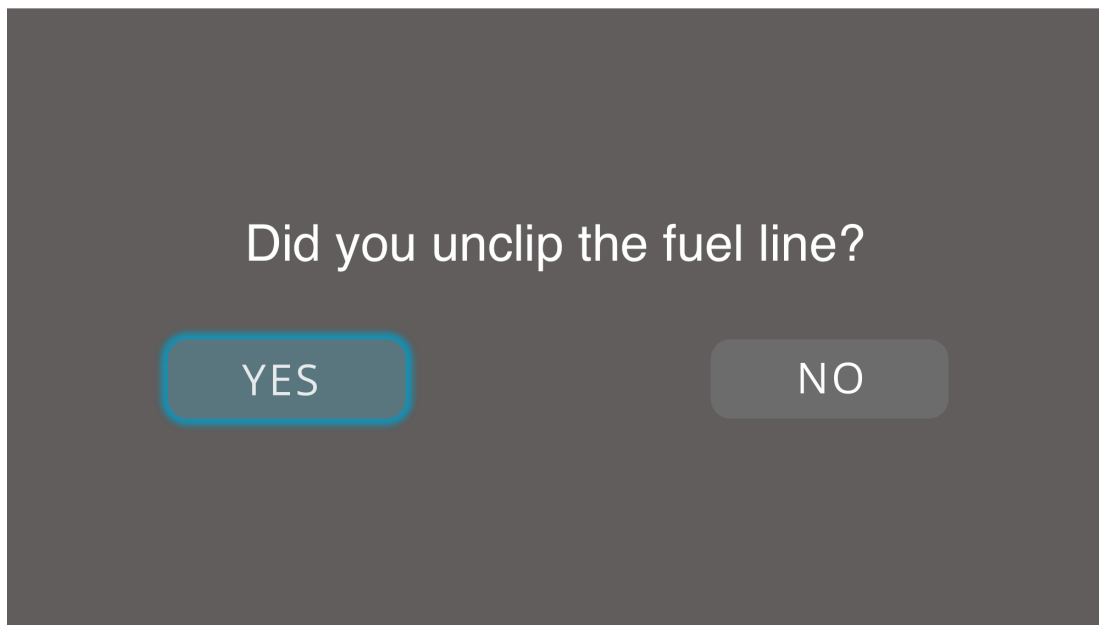

- Make sure the inlet fuel line clip is unclip

5

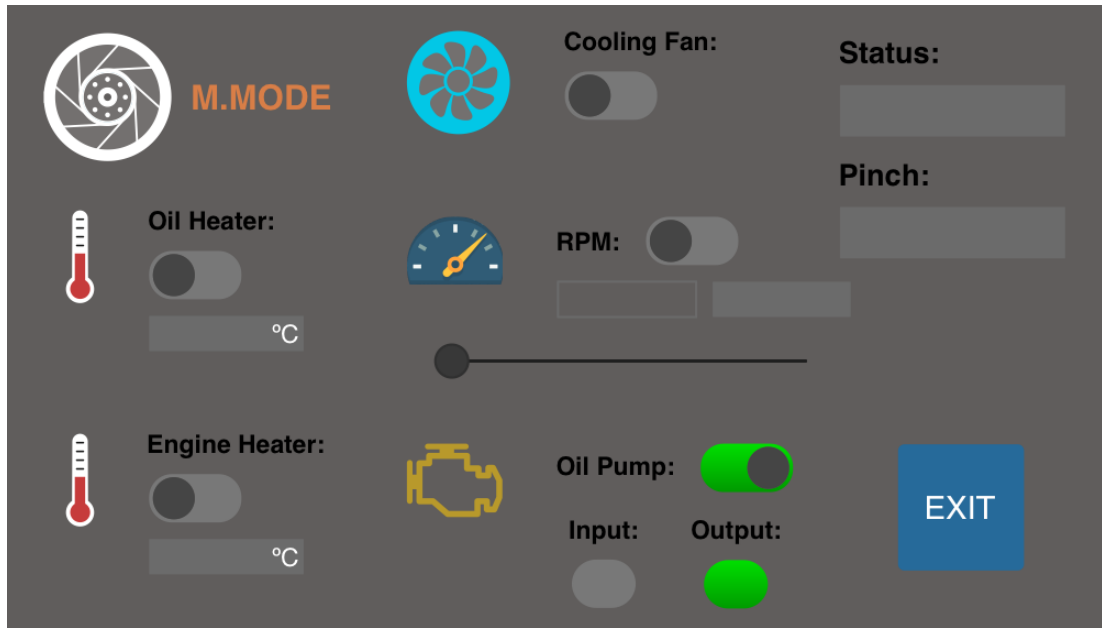

- The oil will start withdraw from the system

# Switch to Oil Bath Module

---

1

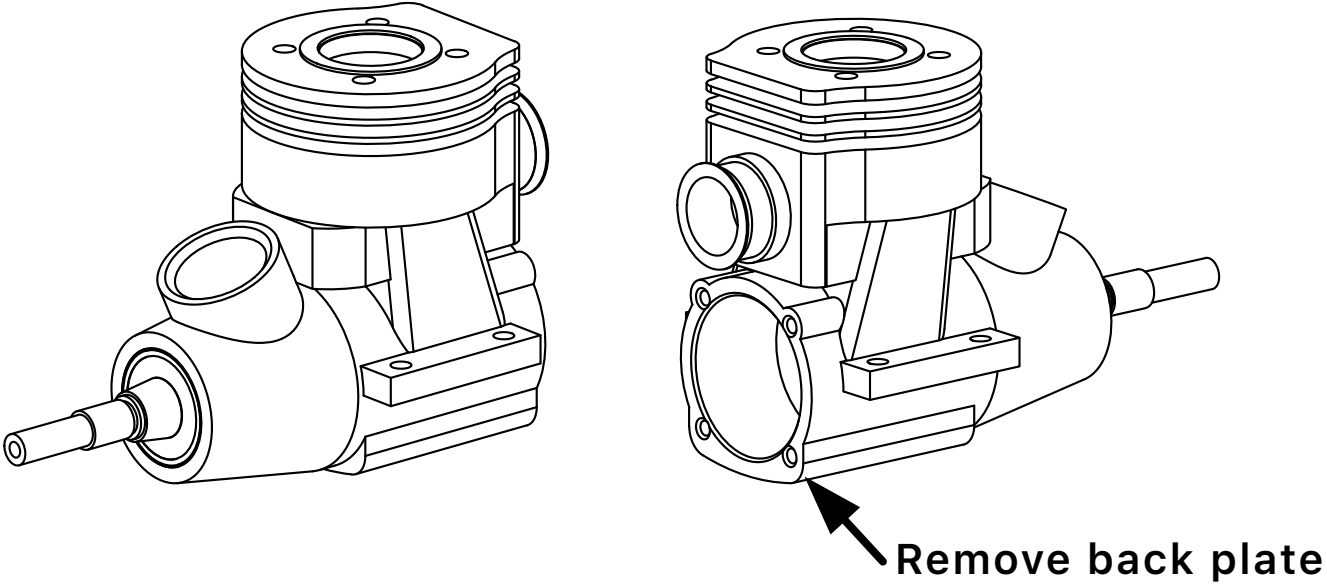

2

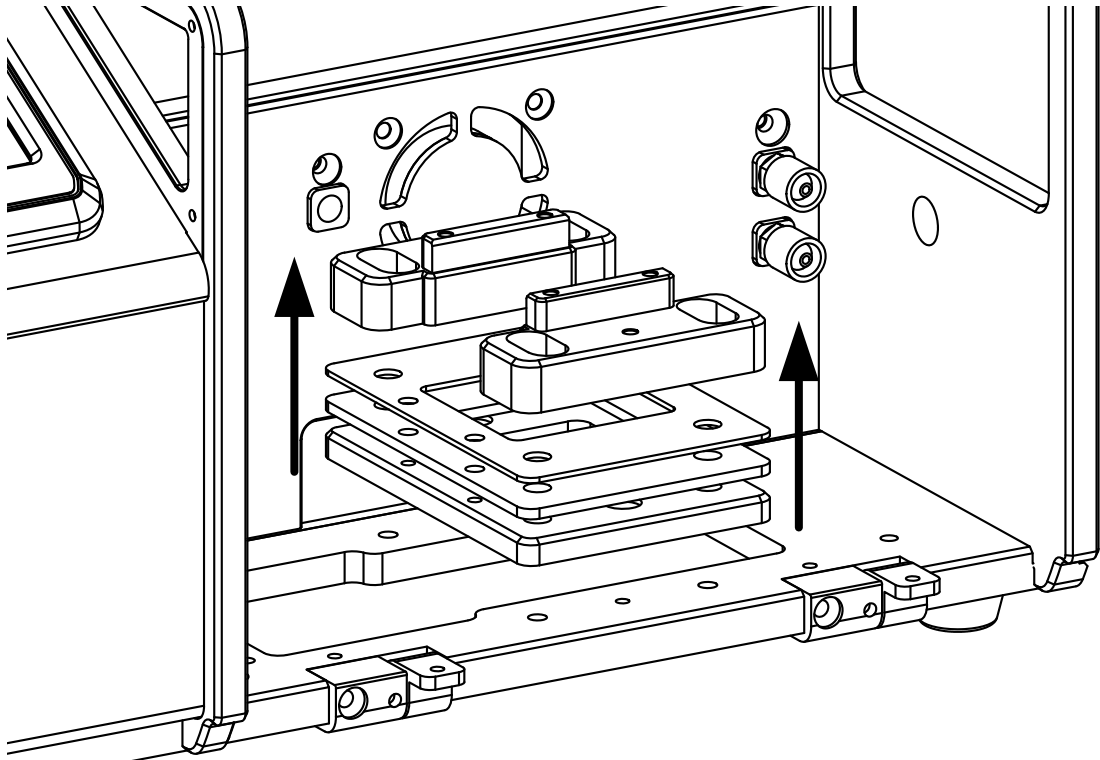

3

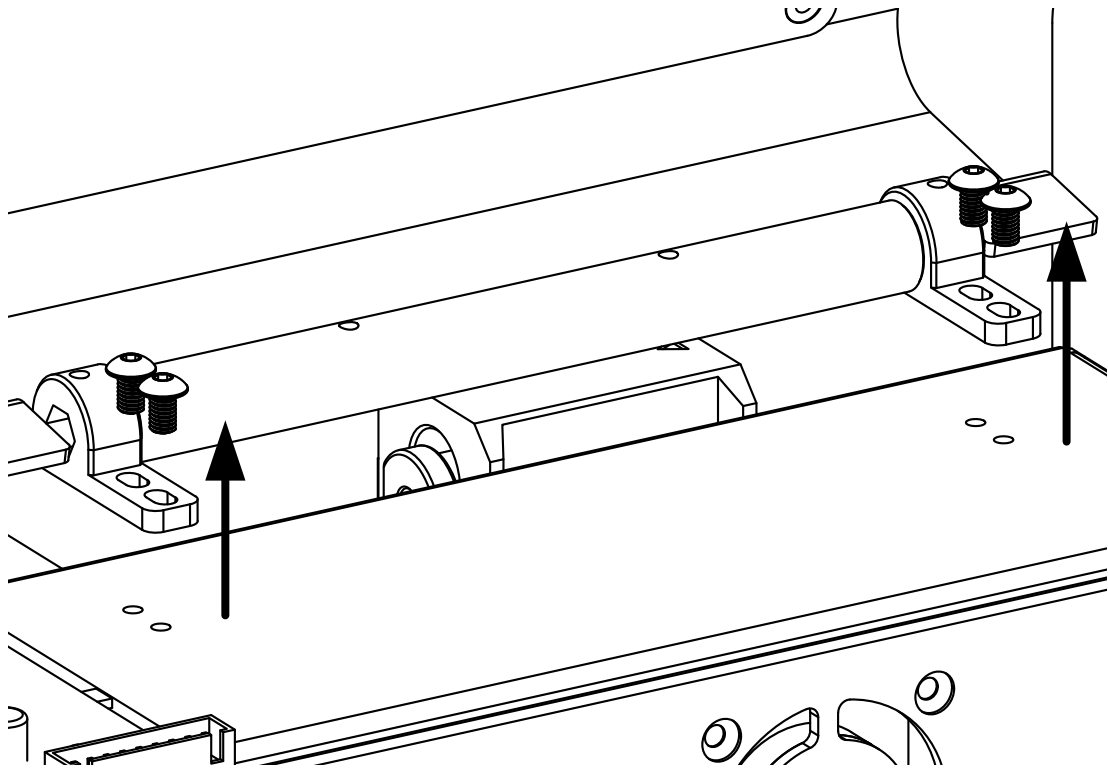

4

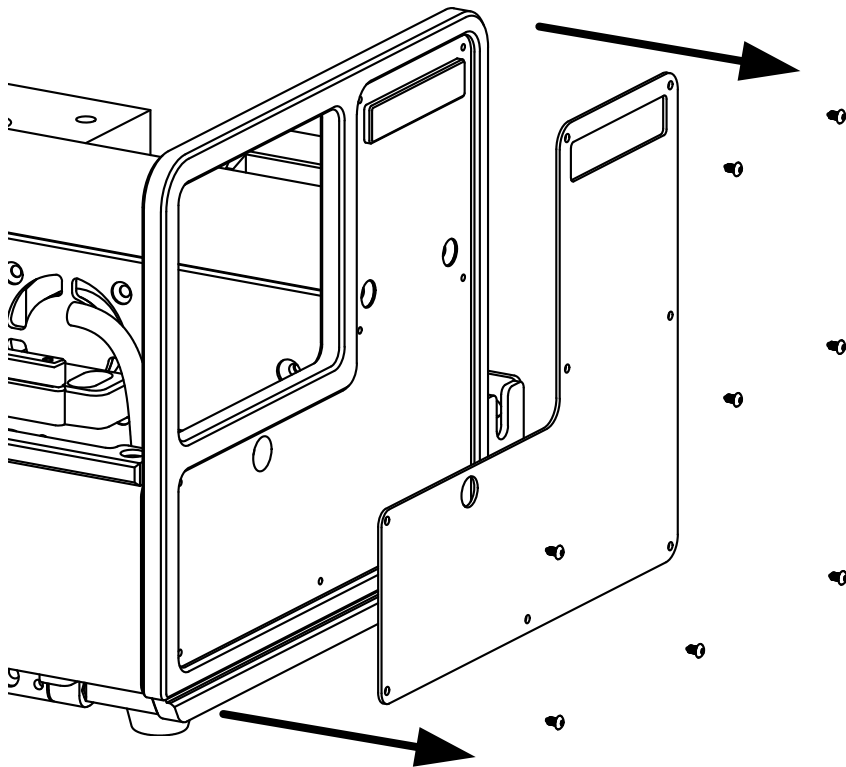

5

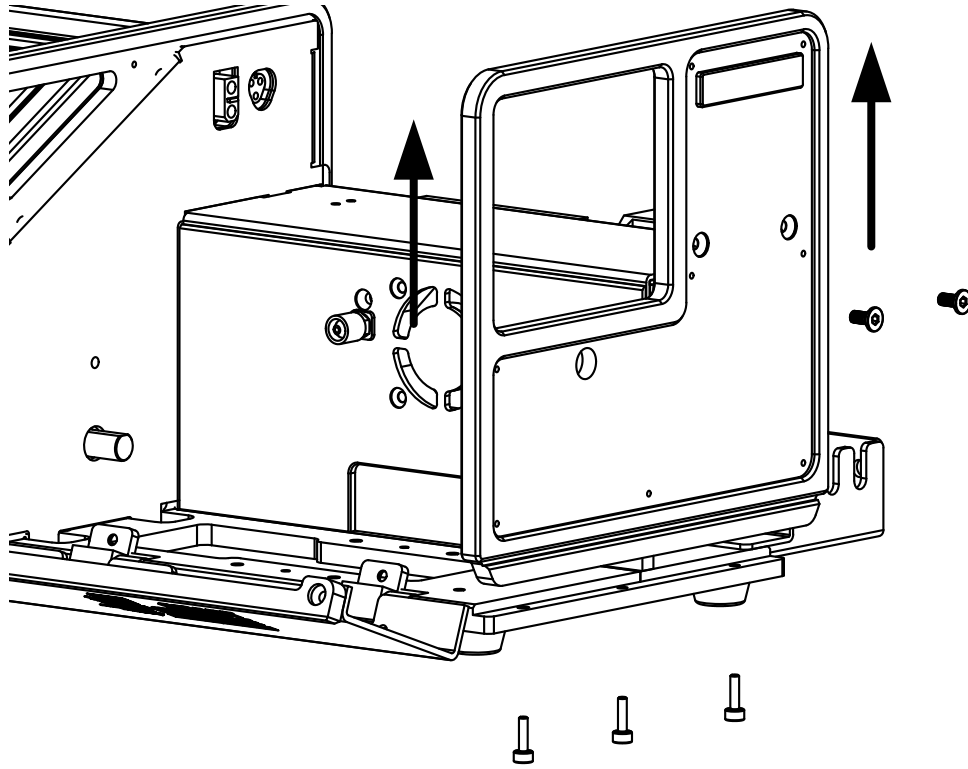

6

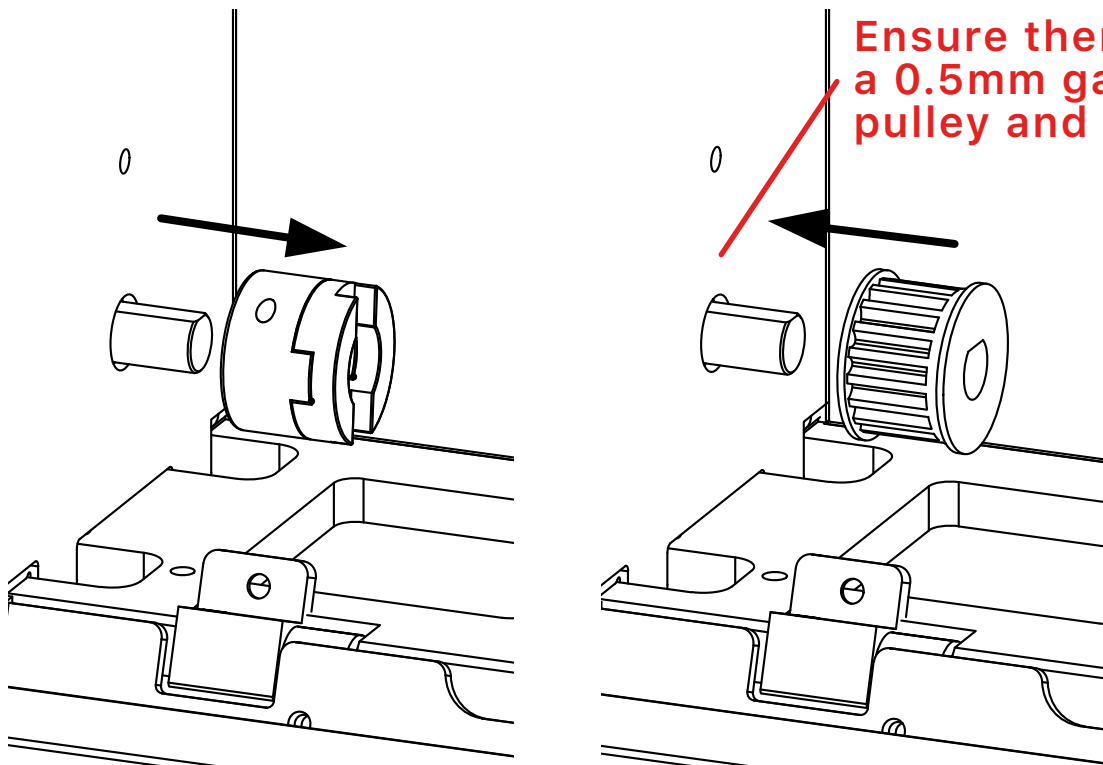



7

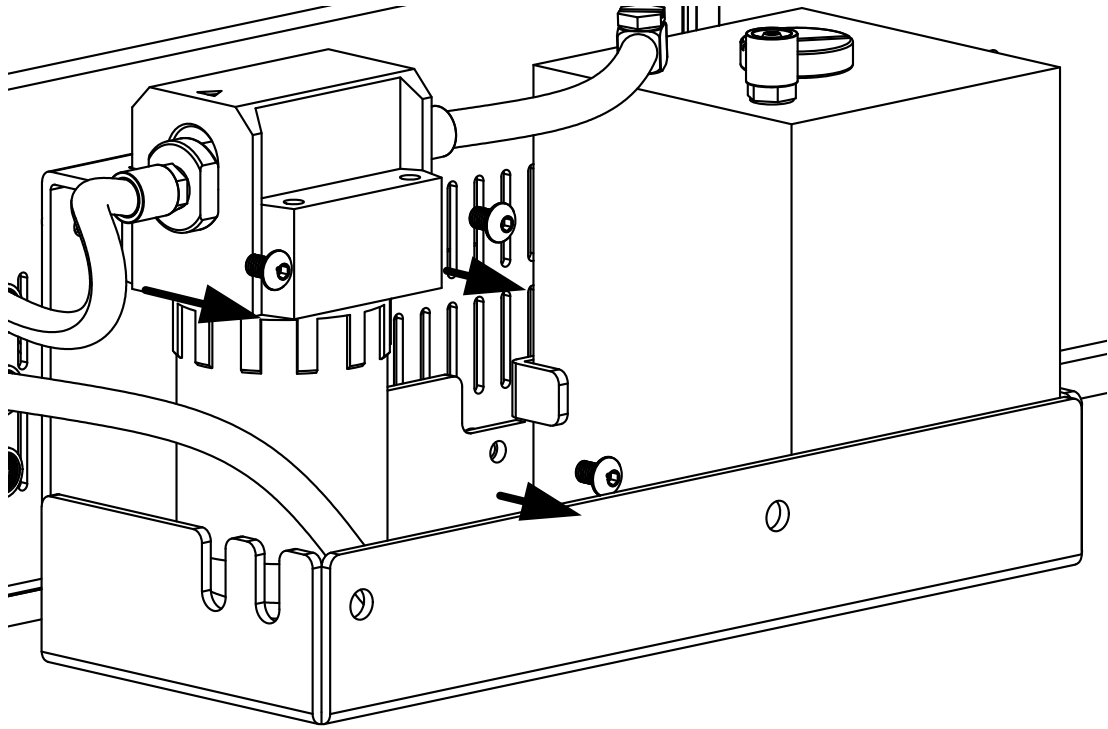

8

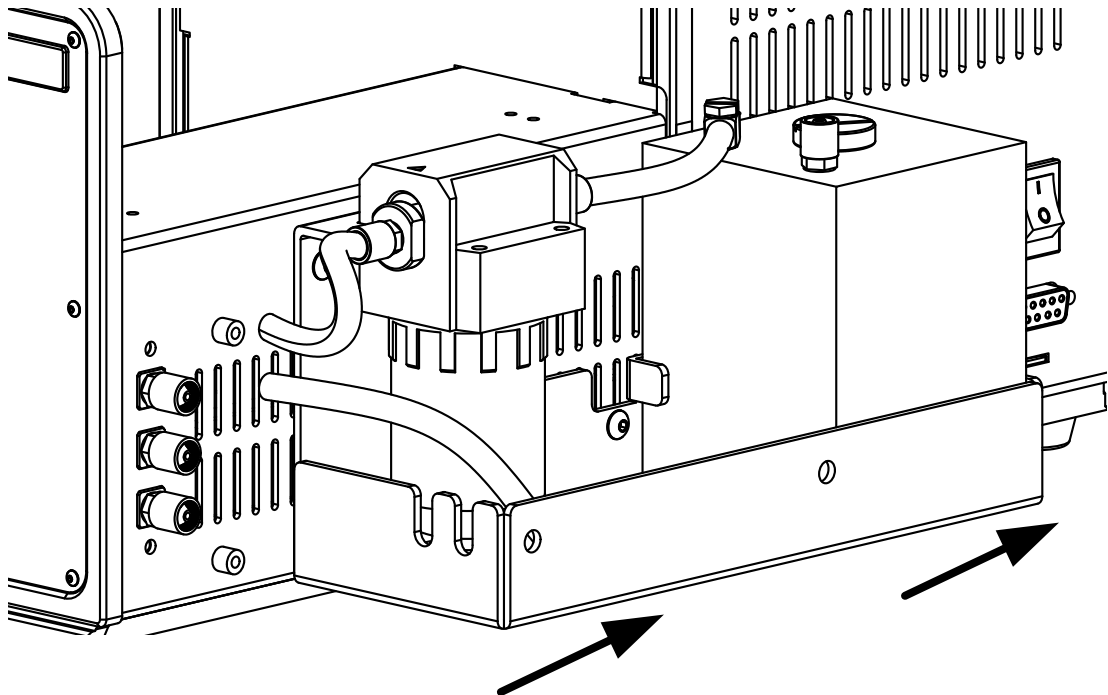

9

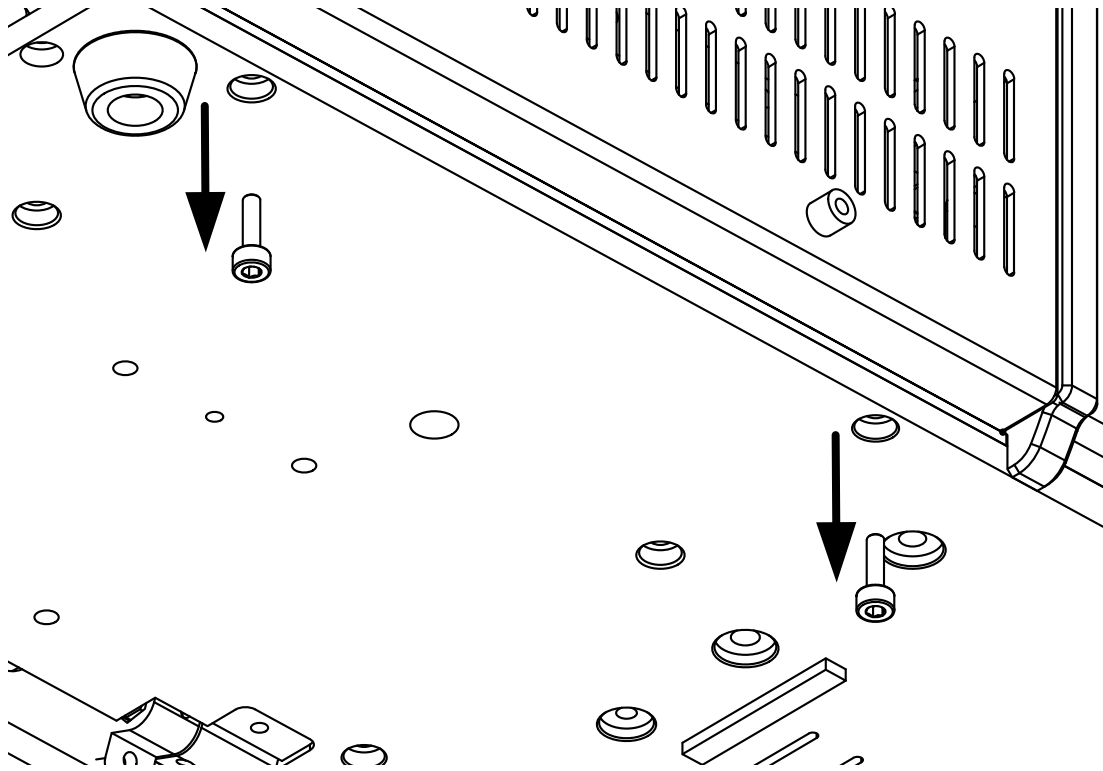

10

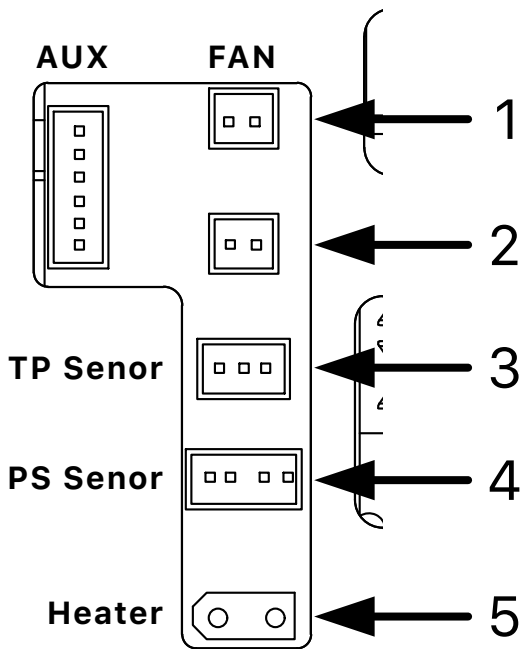

Oil Running

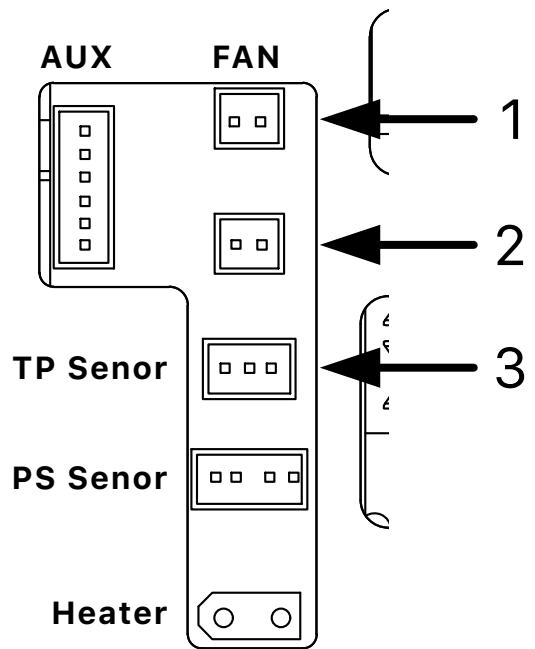

Oil Bath

11

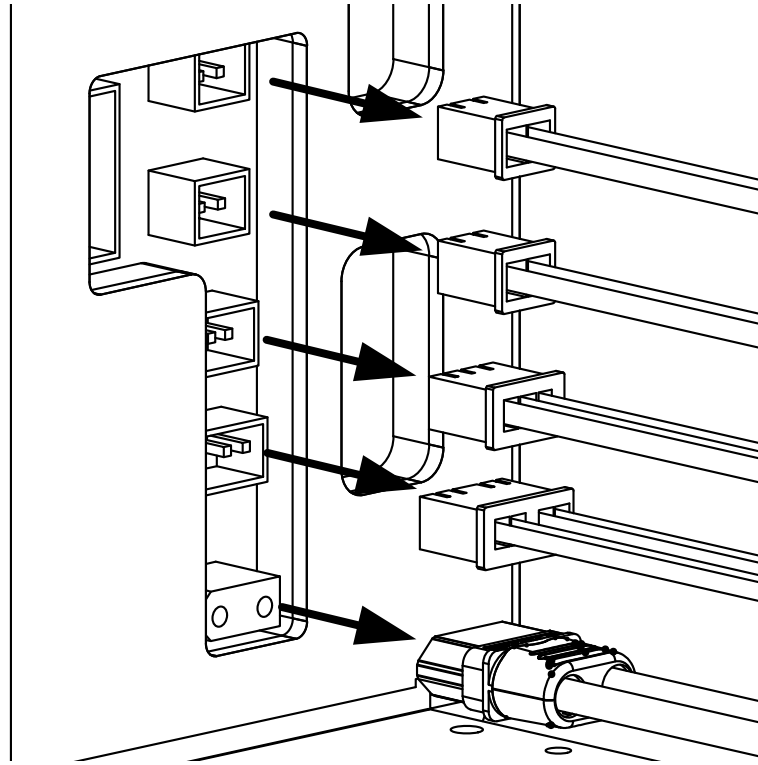

12

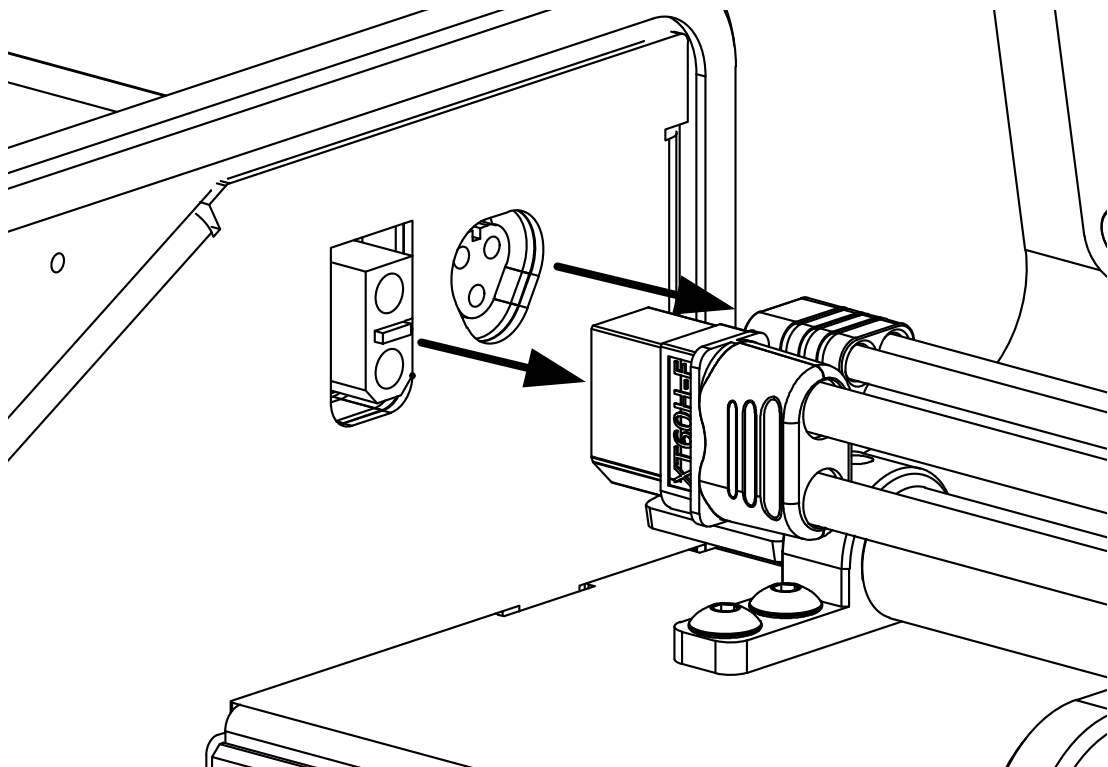

13

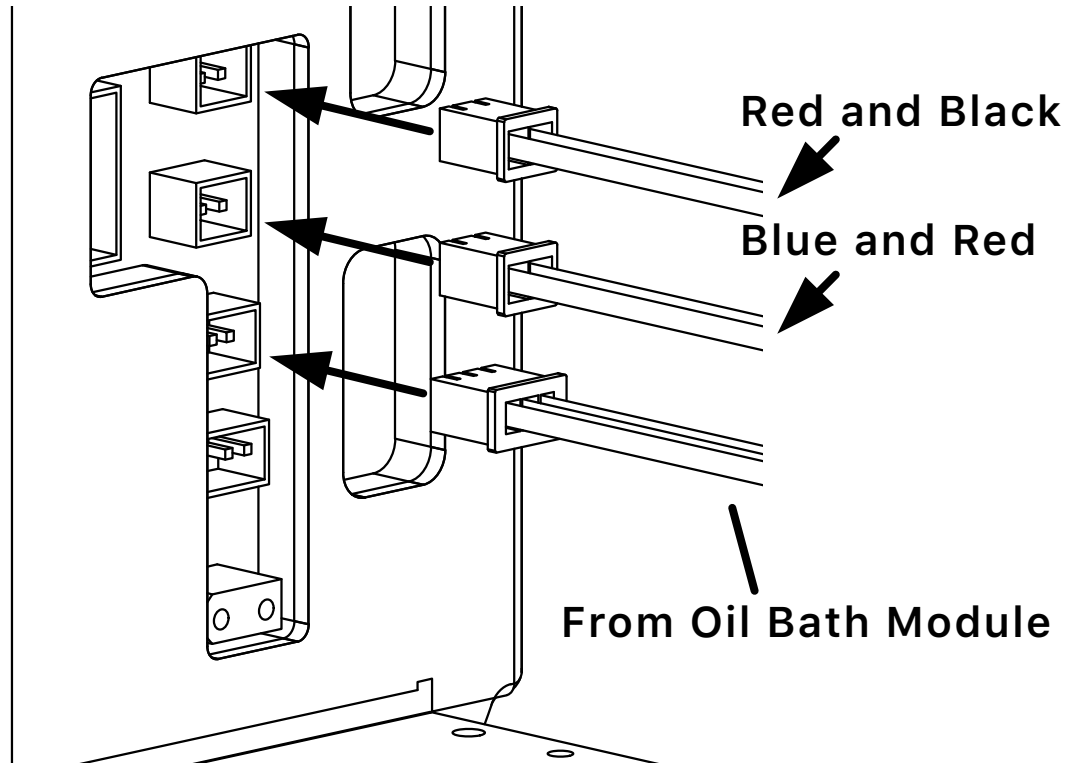

14

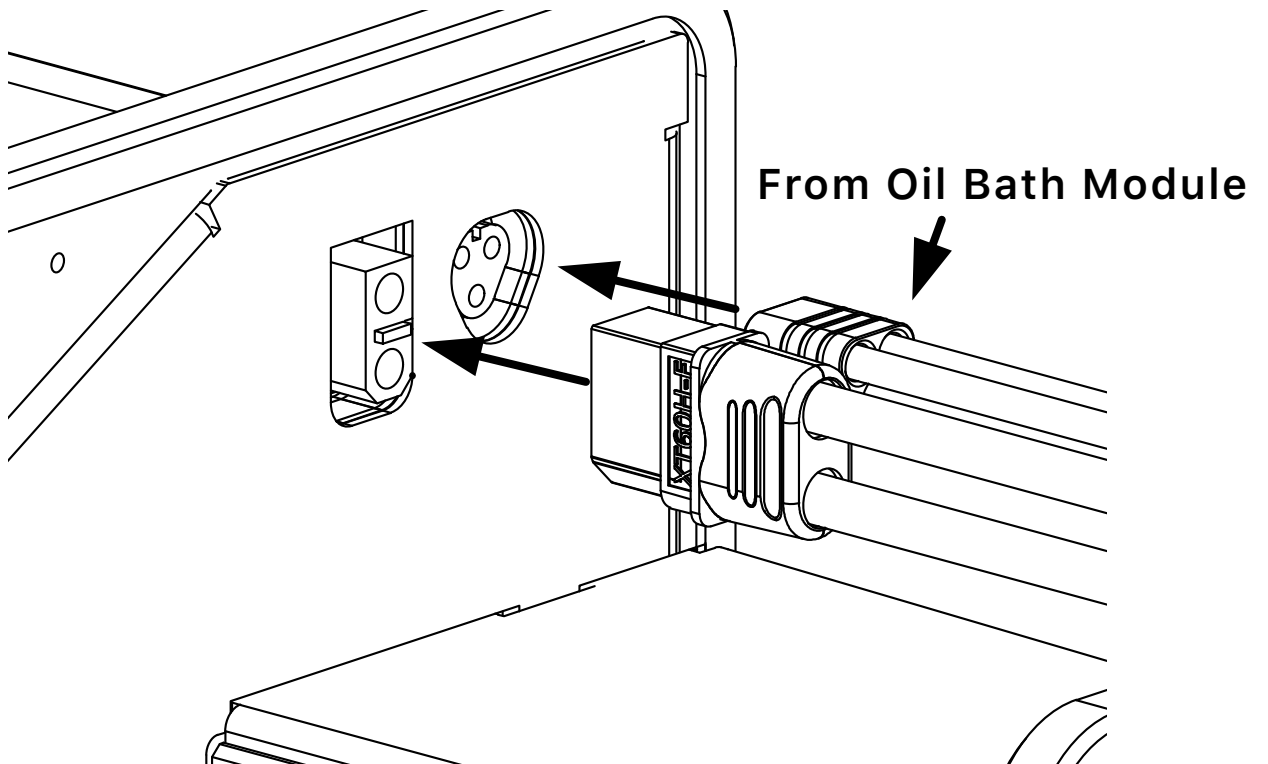

15

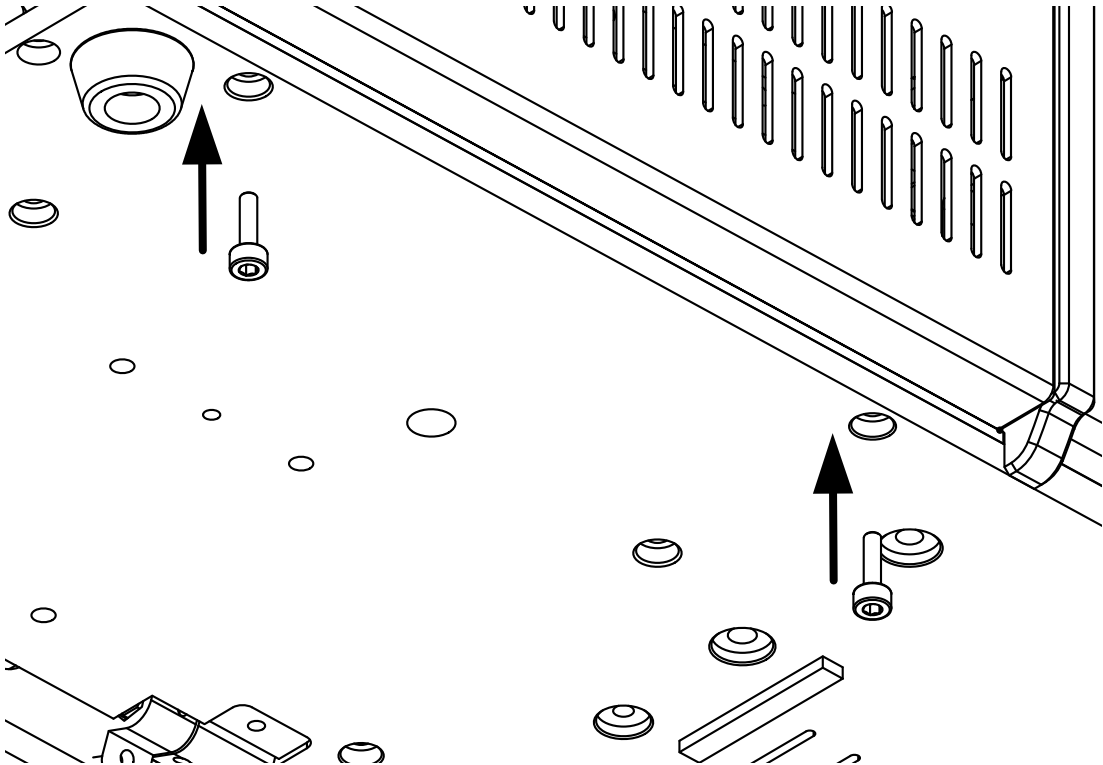

16

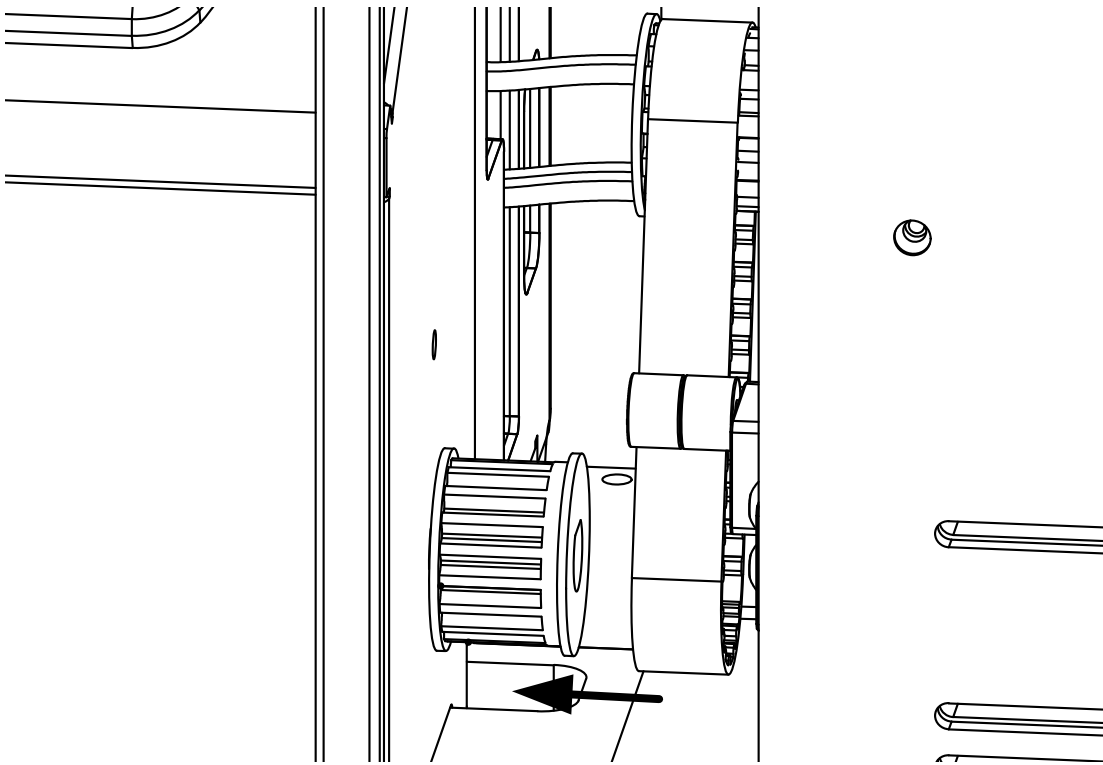

# 17

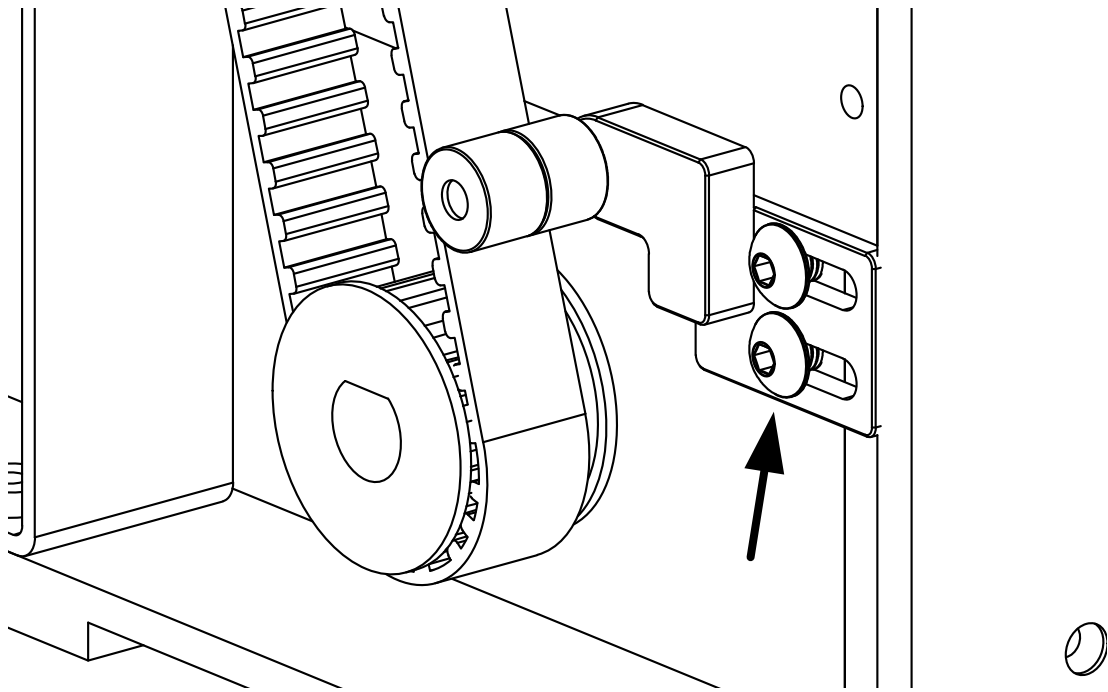

- Adjust the belt tension

---

# 18

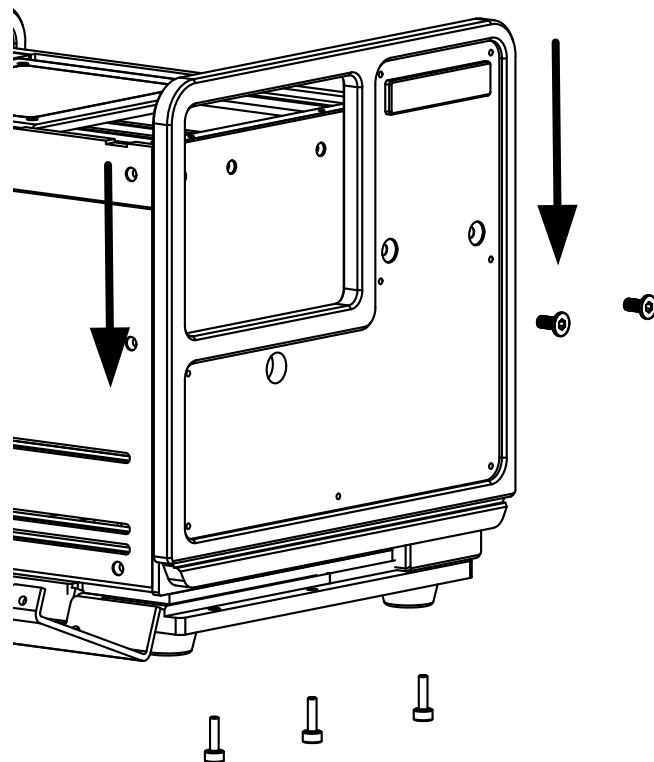

19

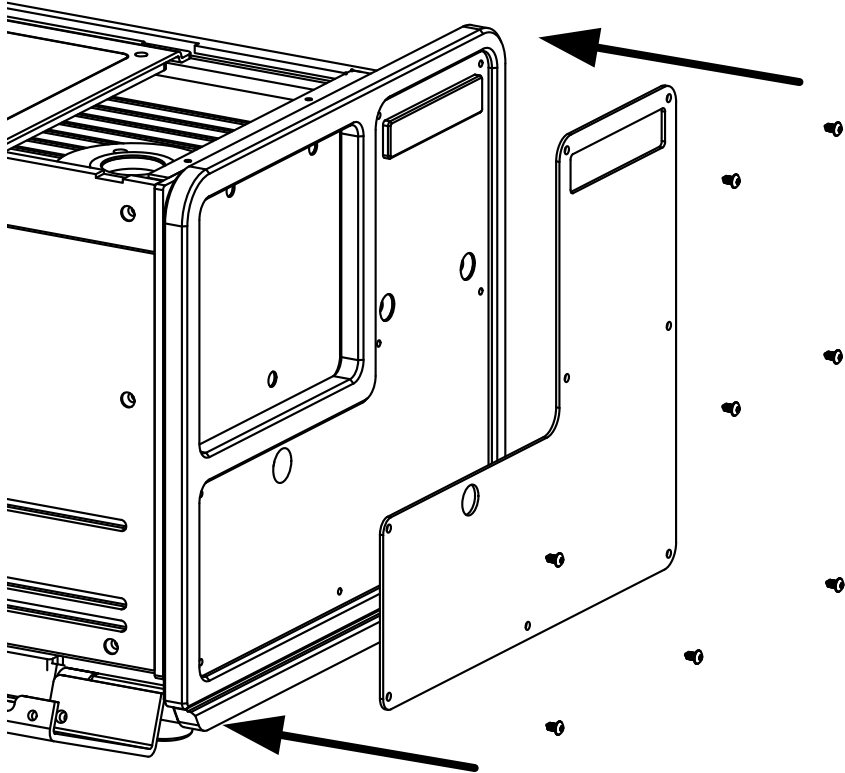

20

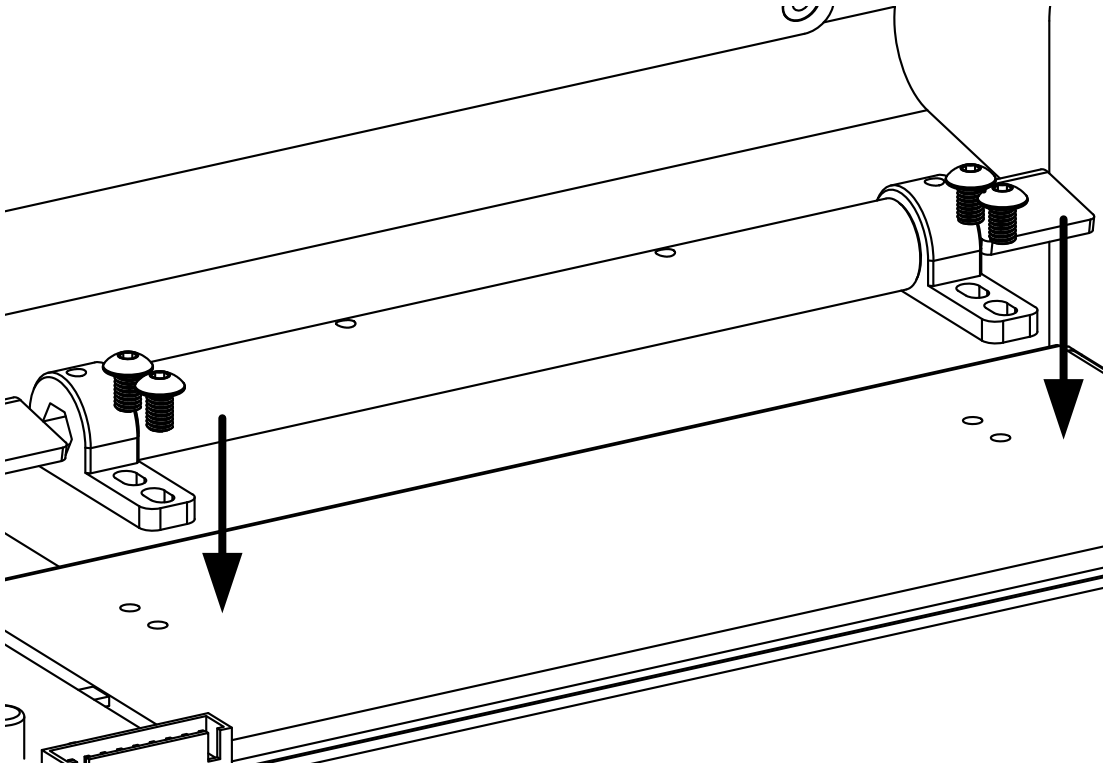

21

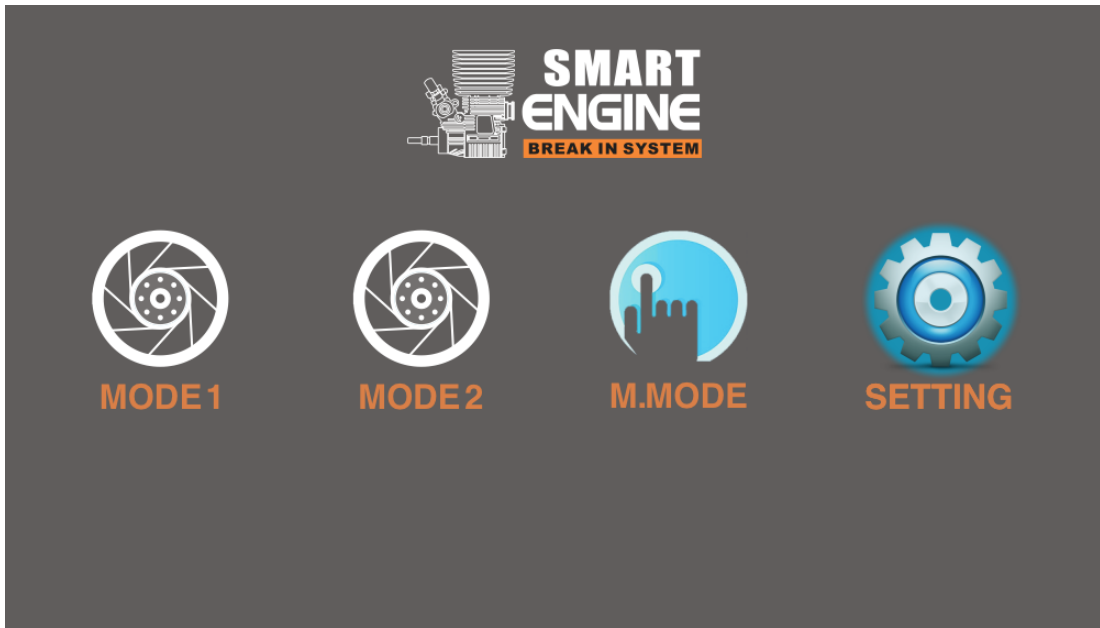

22

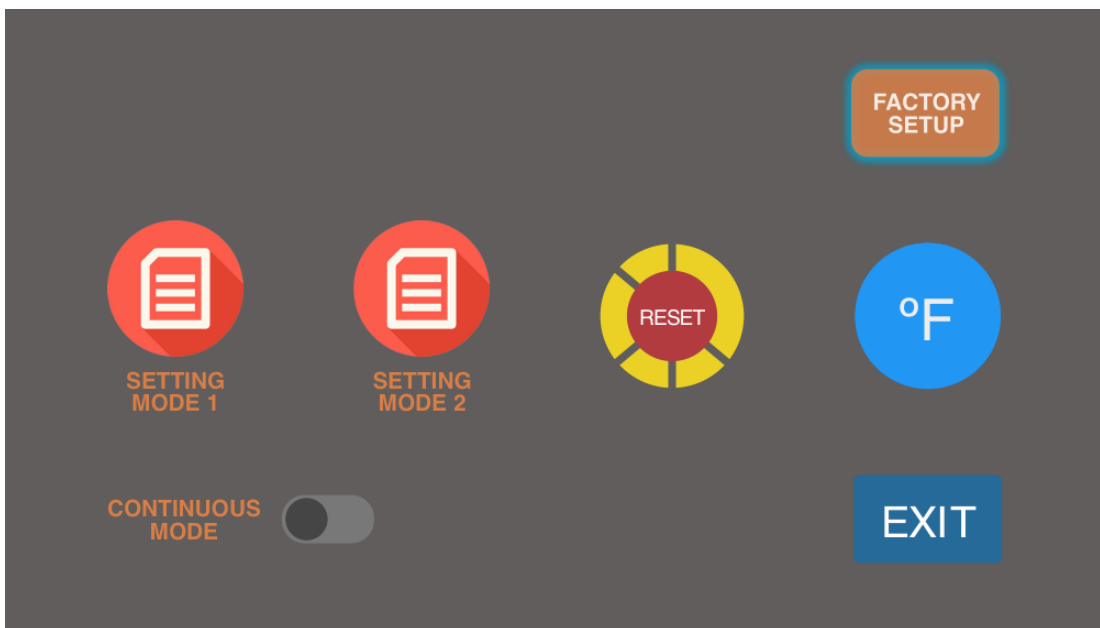



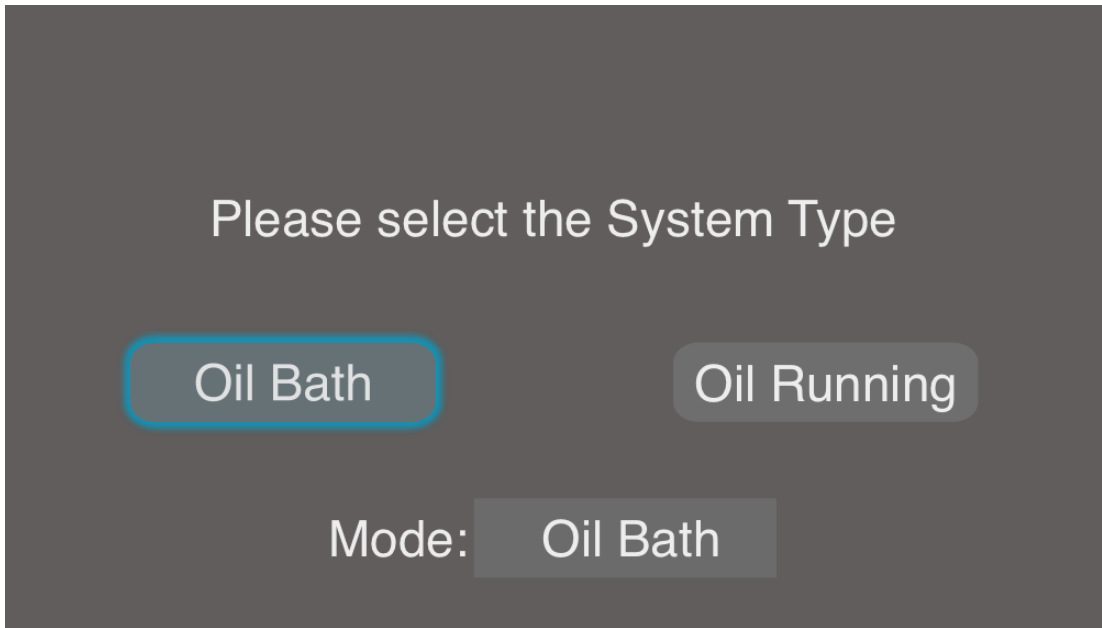

# Switch to Oil Running Module

---

1

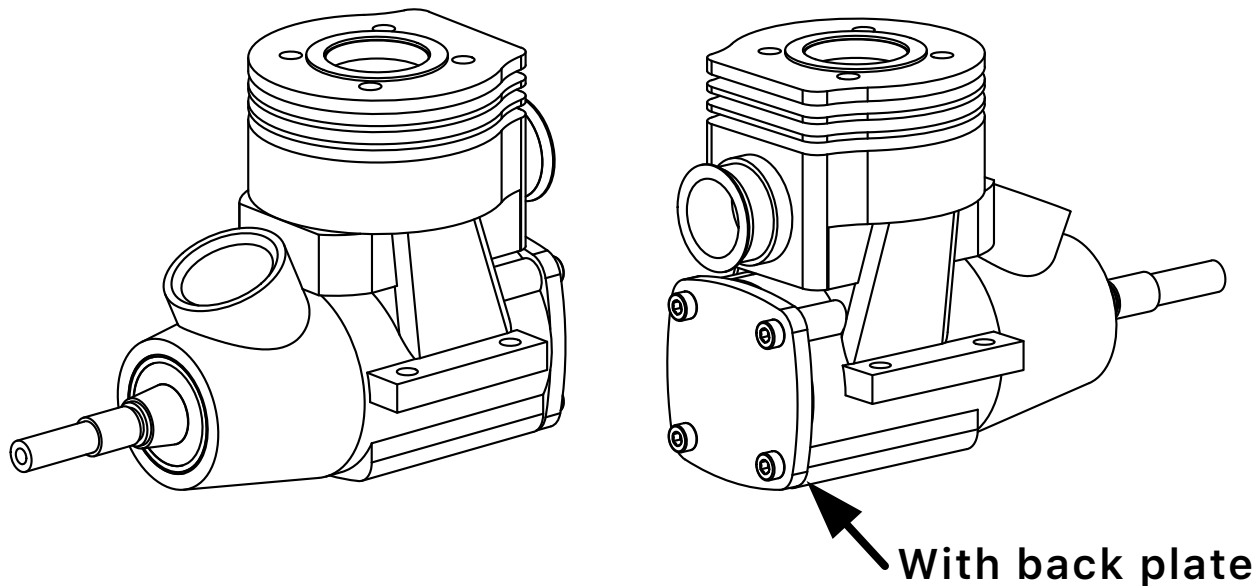

2

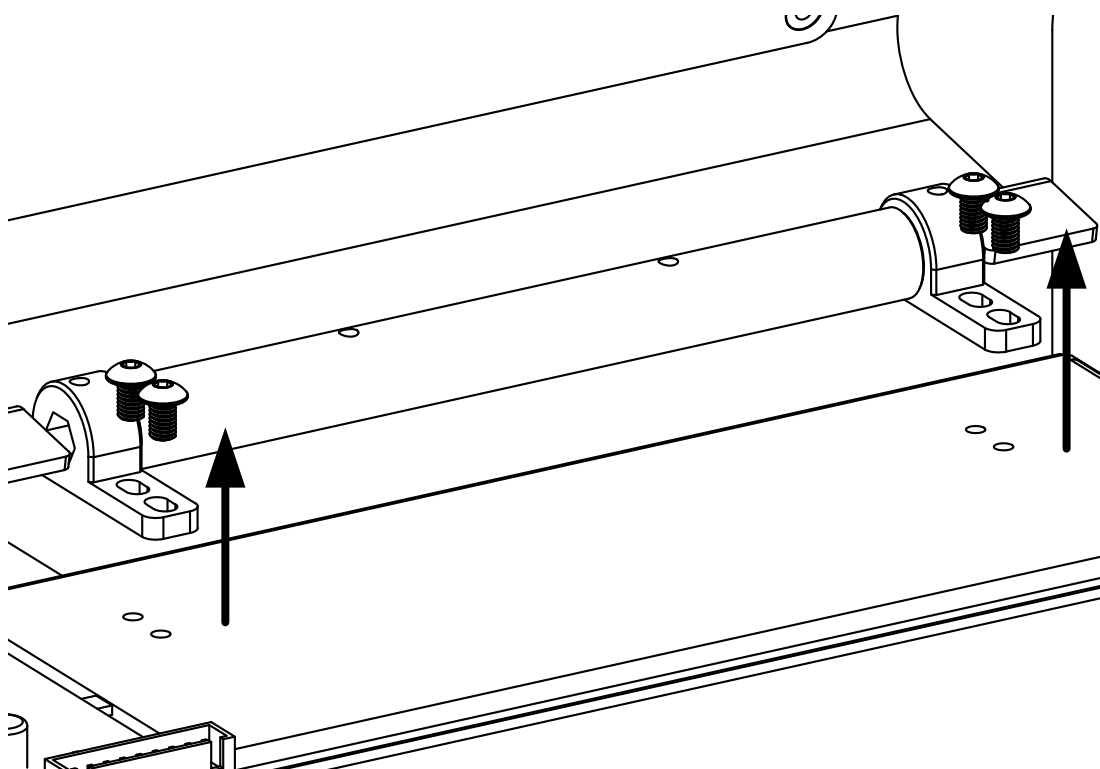

3

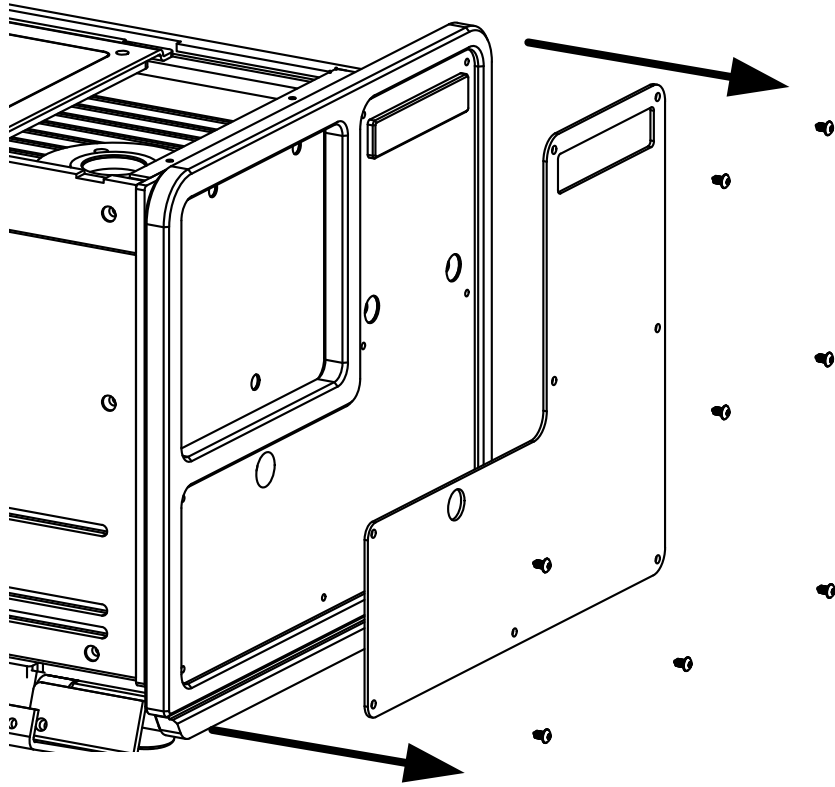

4

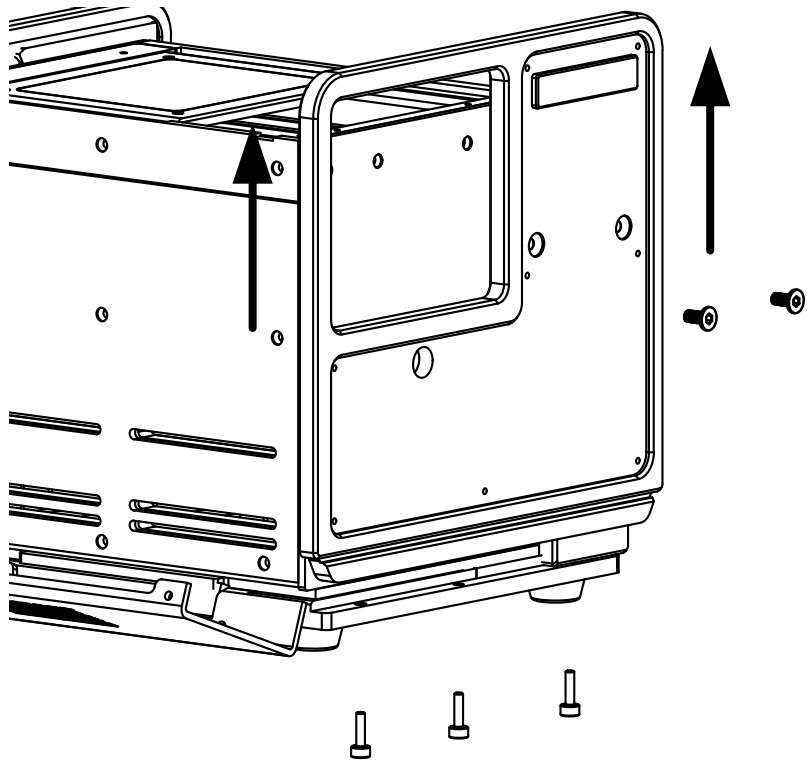

5

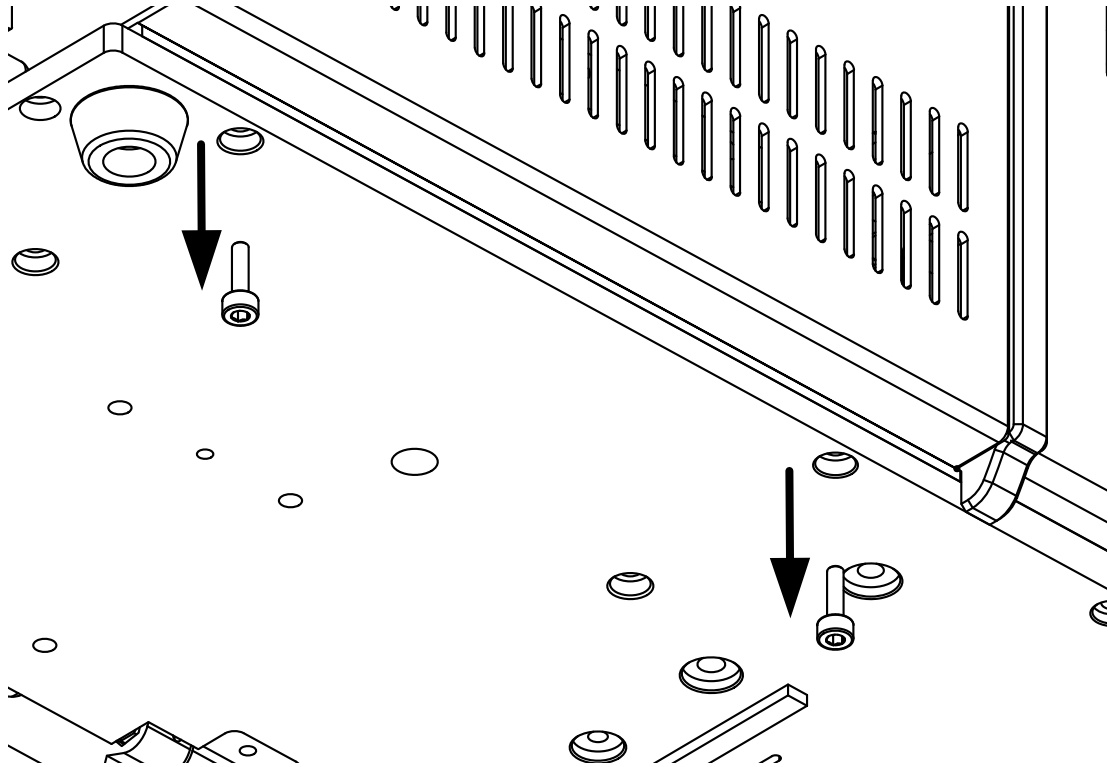

6

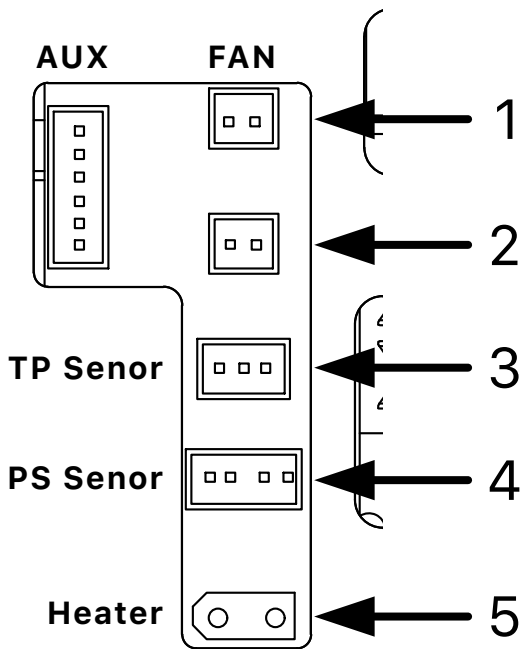

Oil Running

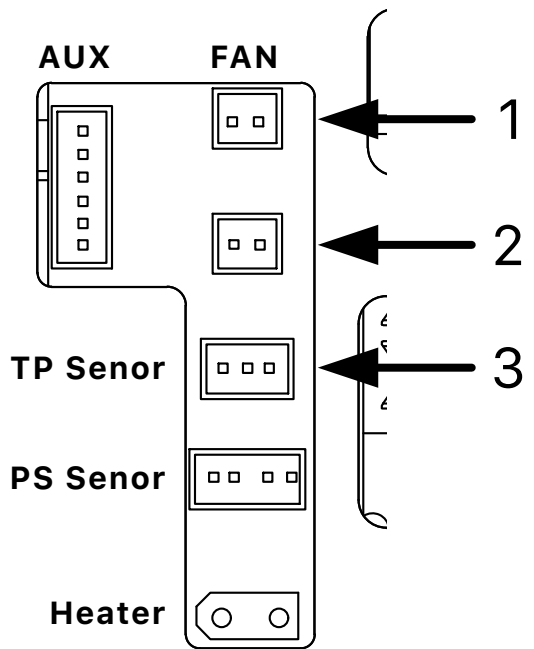

Oil Bath

7

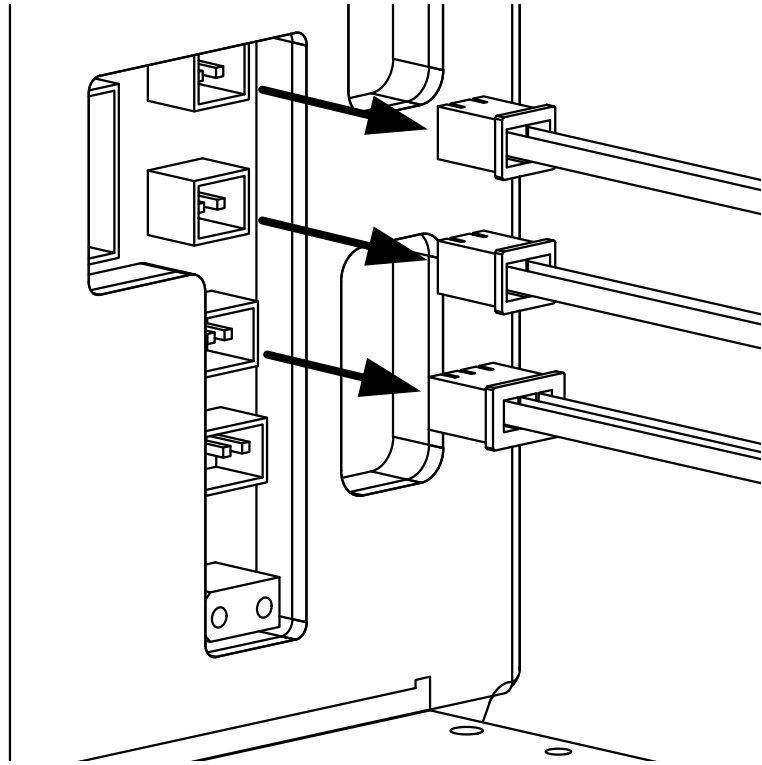

8

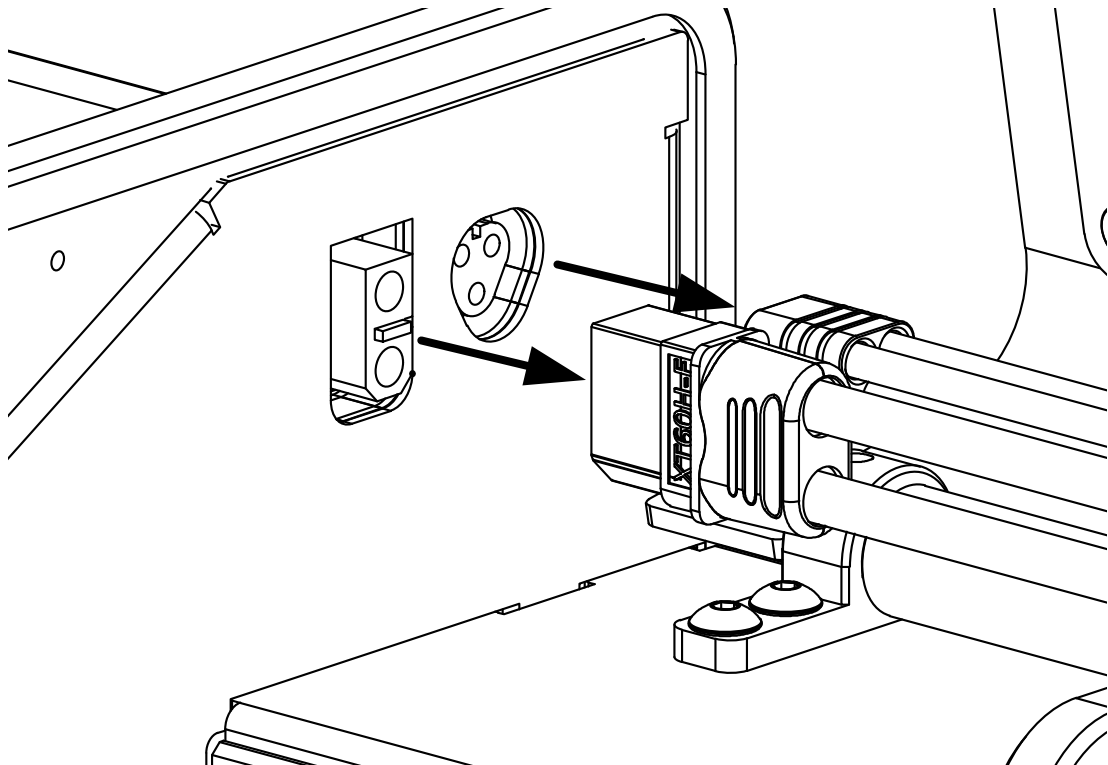

9

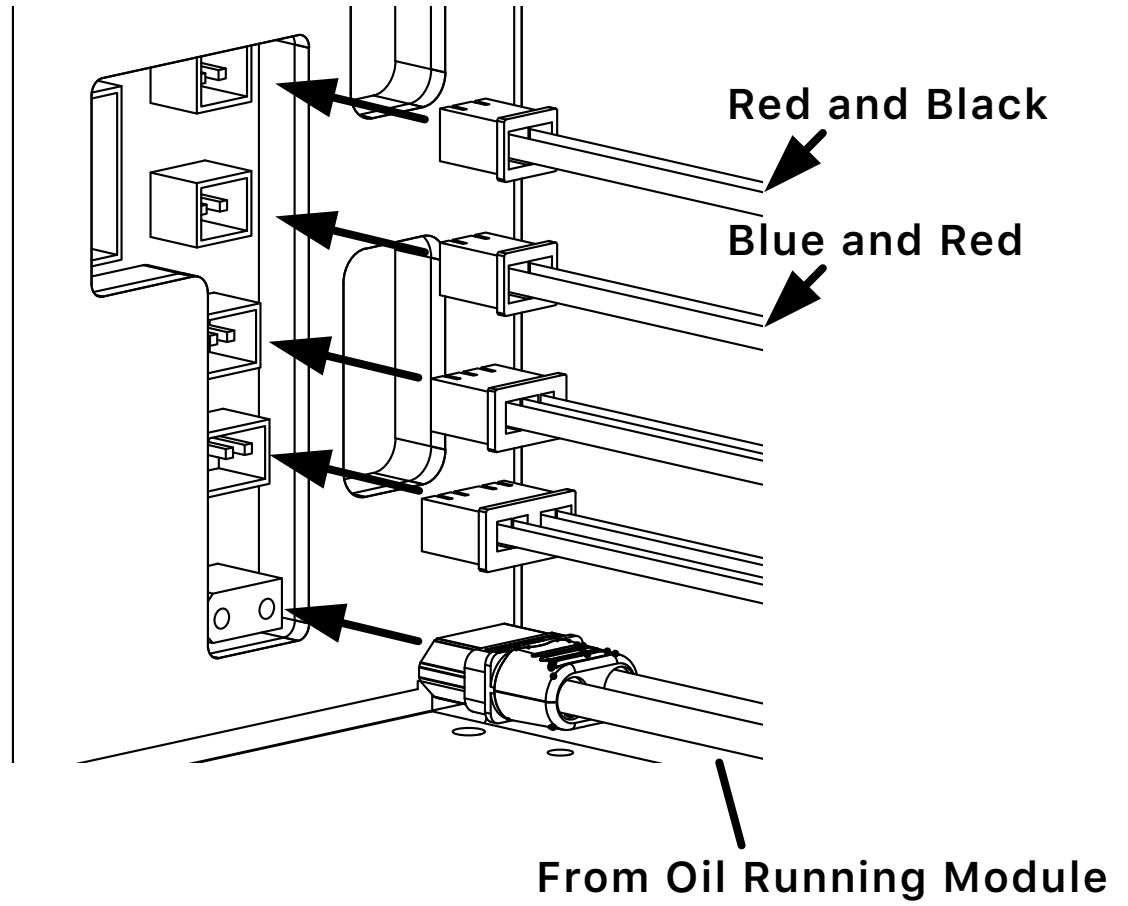

10

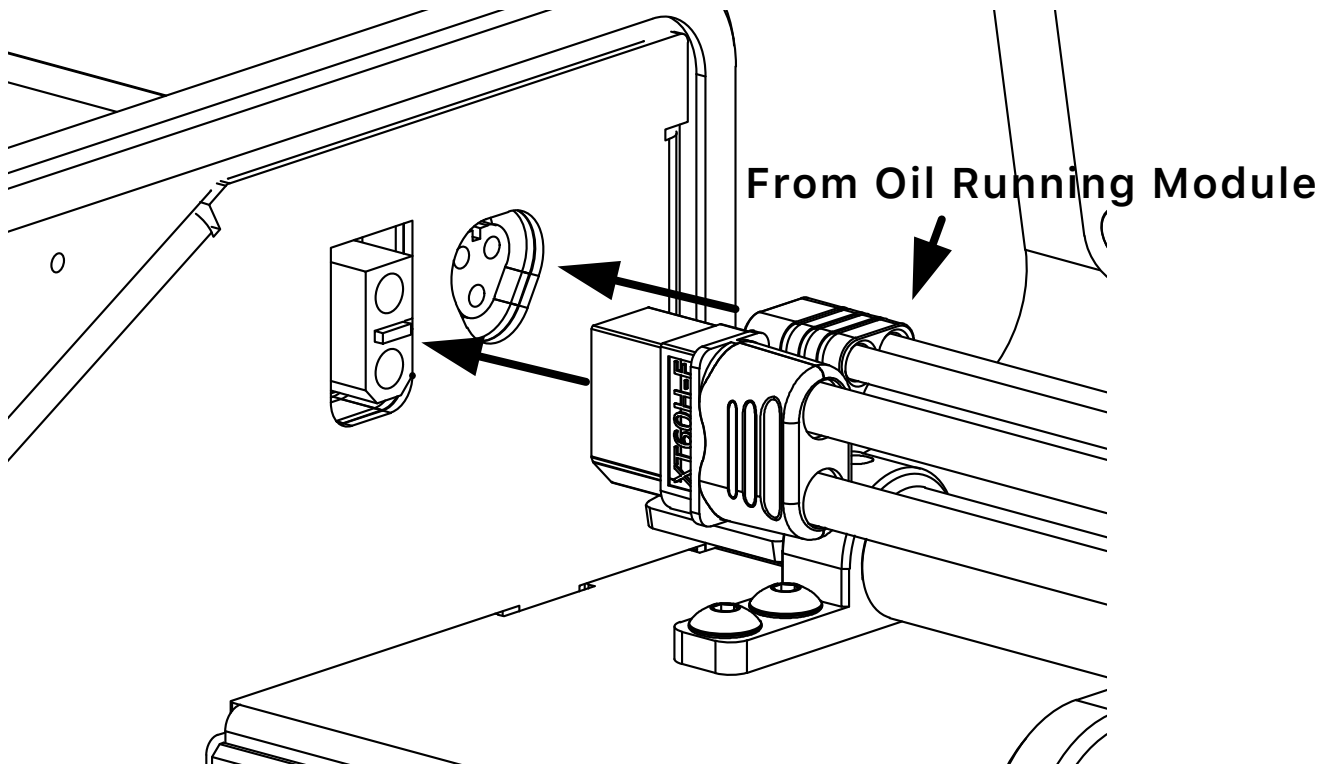

11

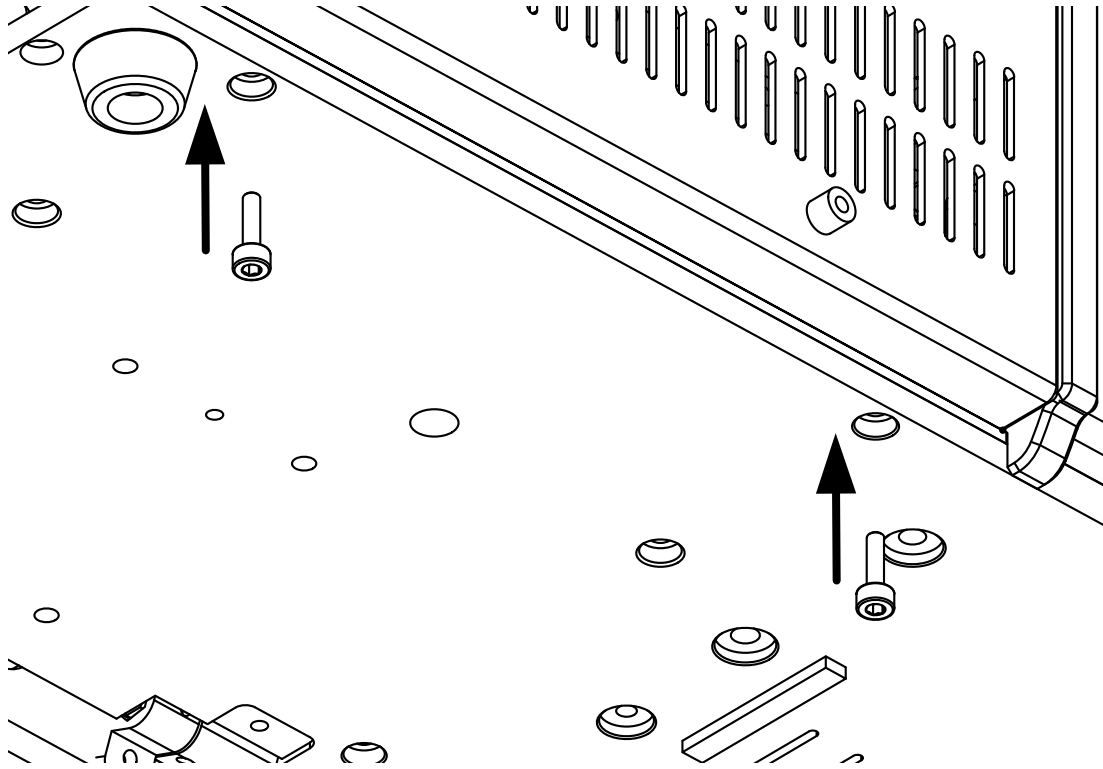

12

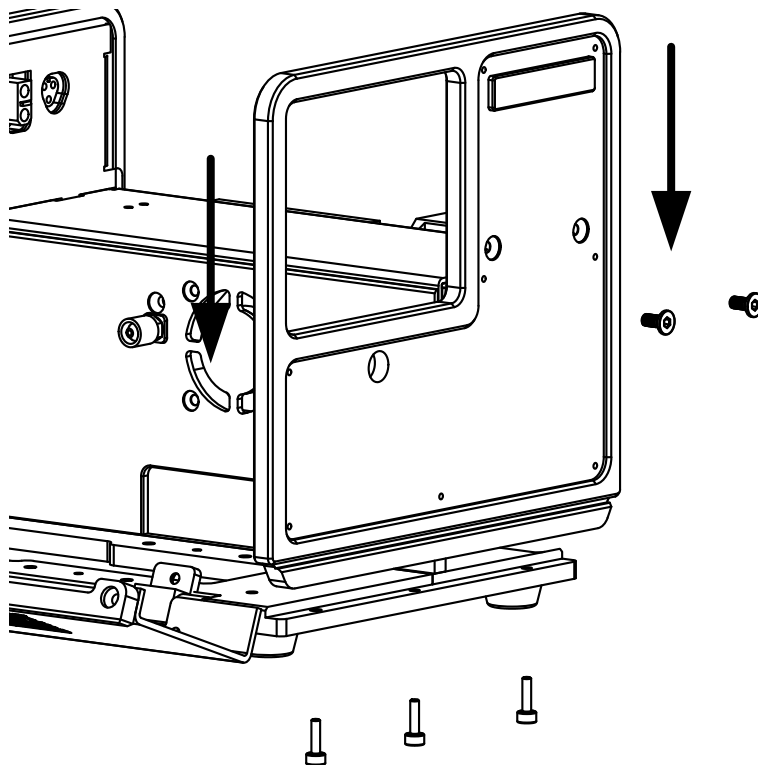

13

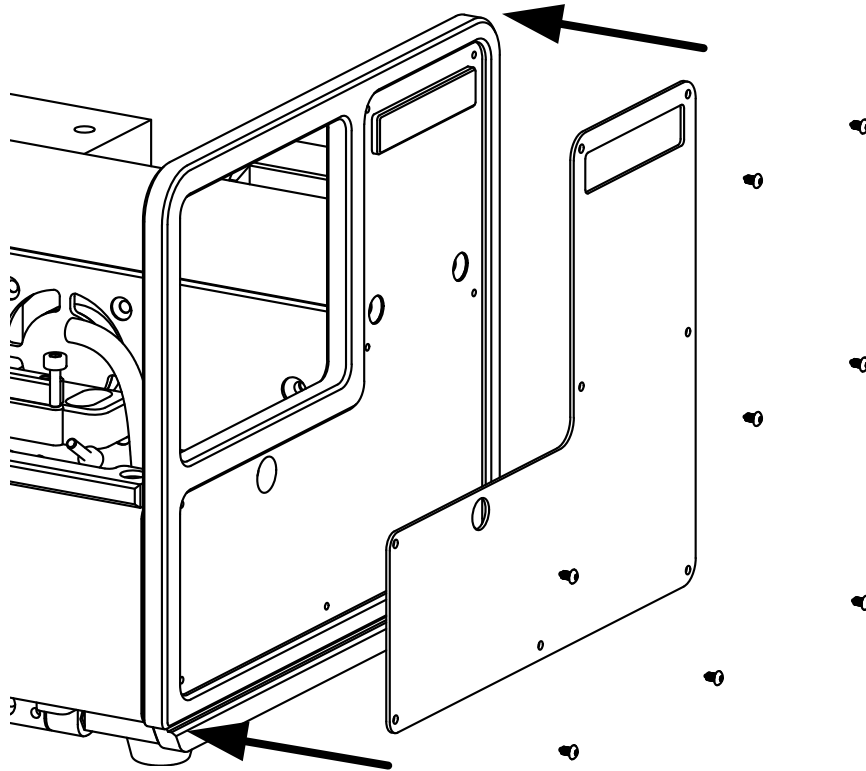

14

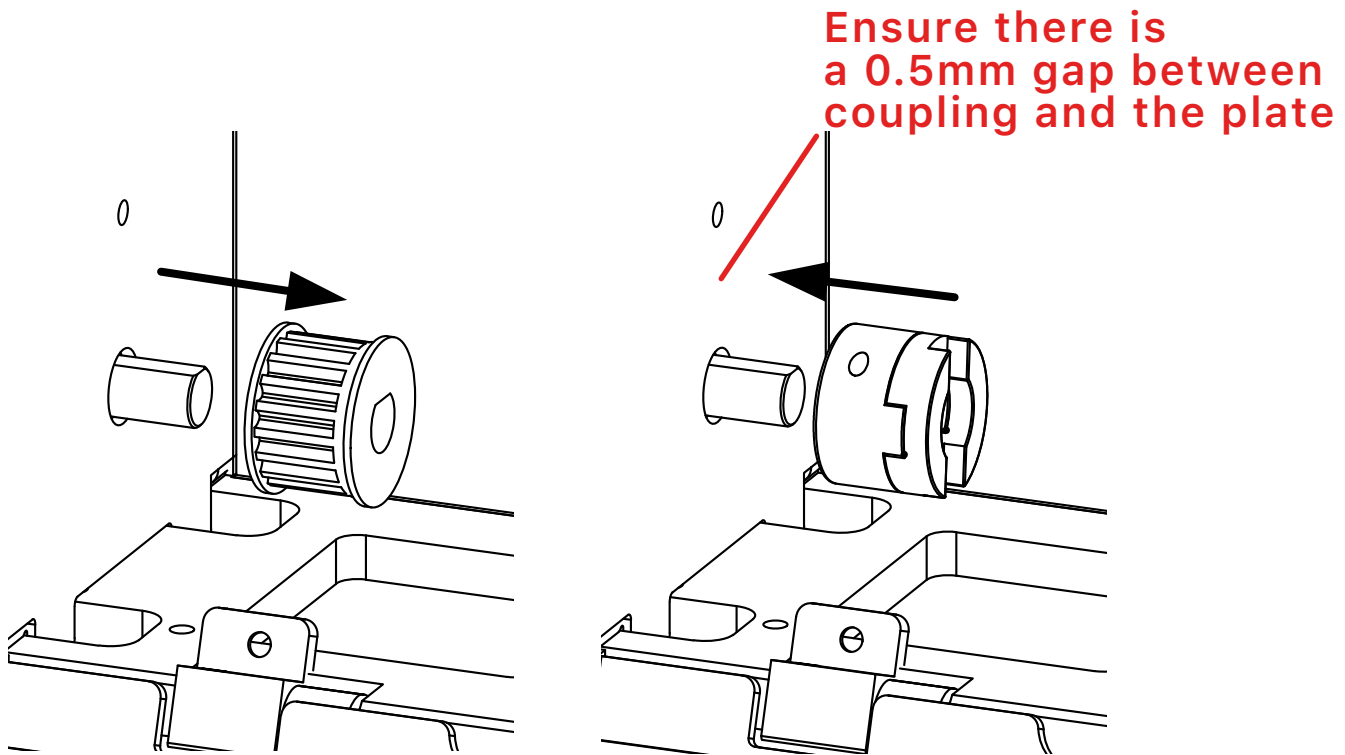

\*Heat up the pulley before unscrewing the set screw



15

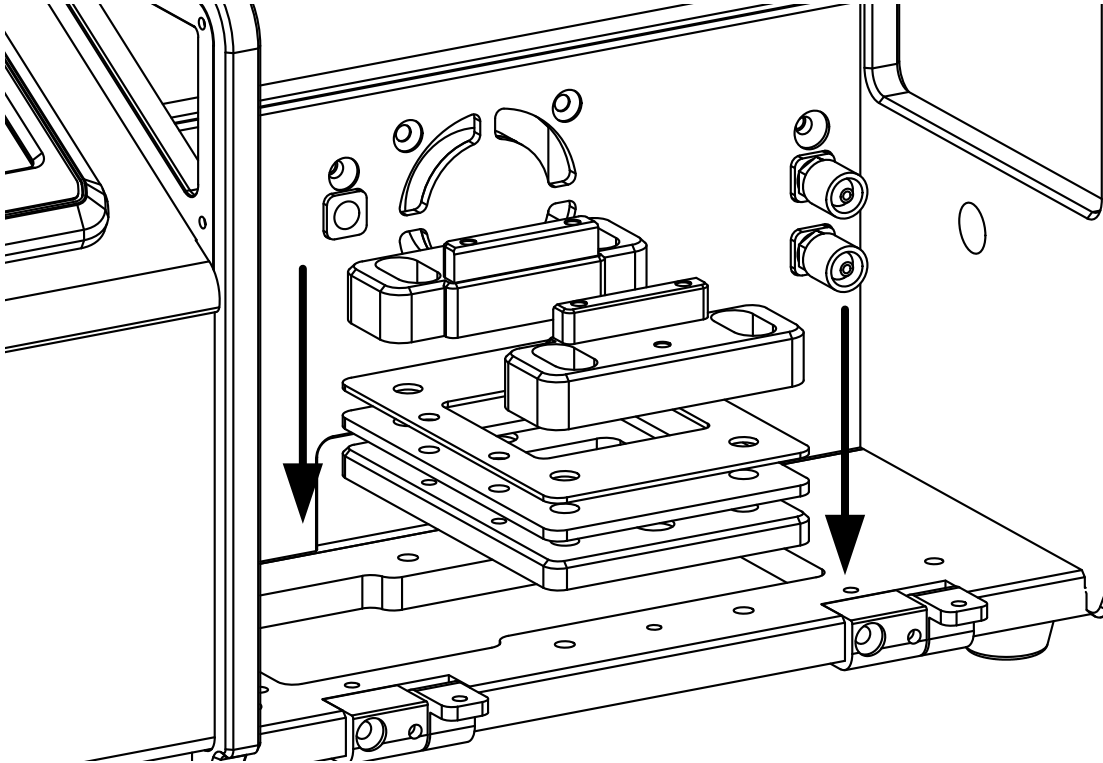

16

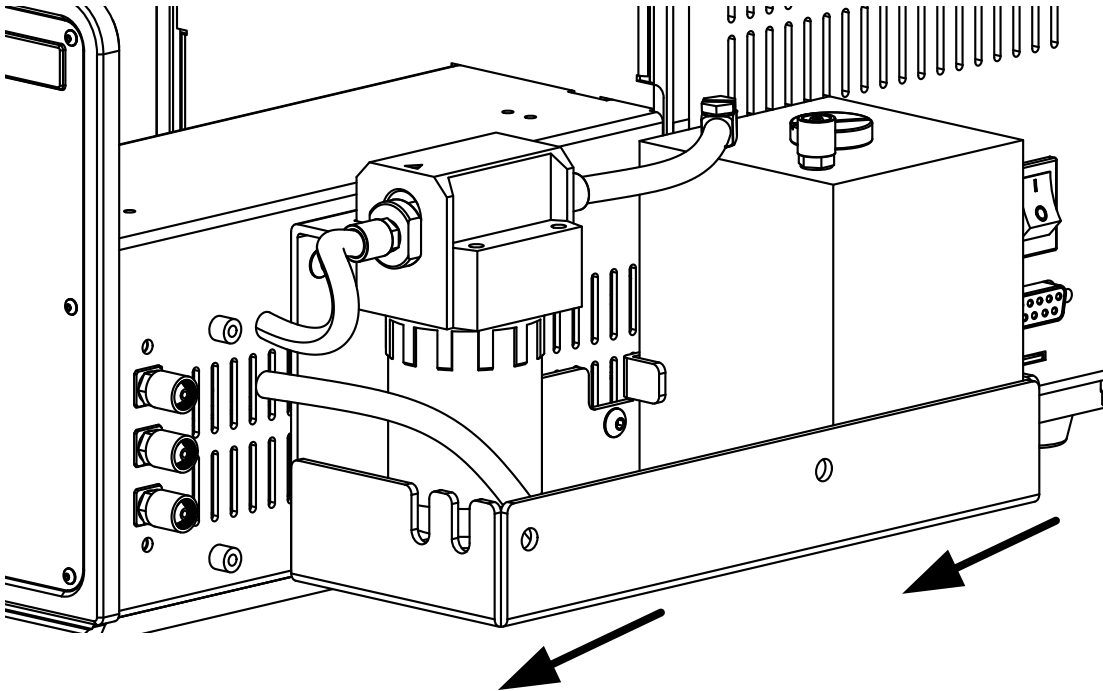

17

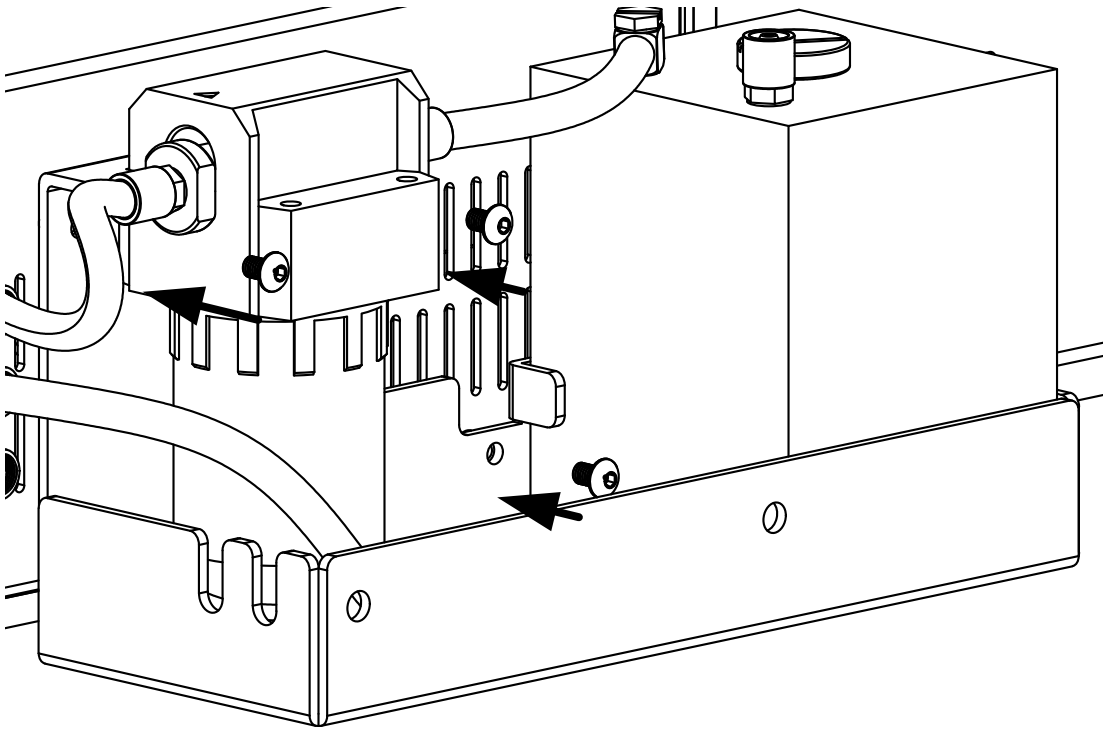

18

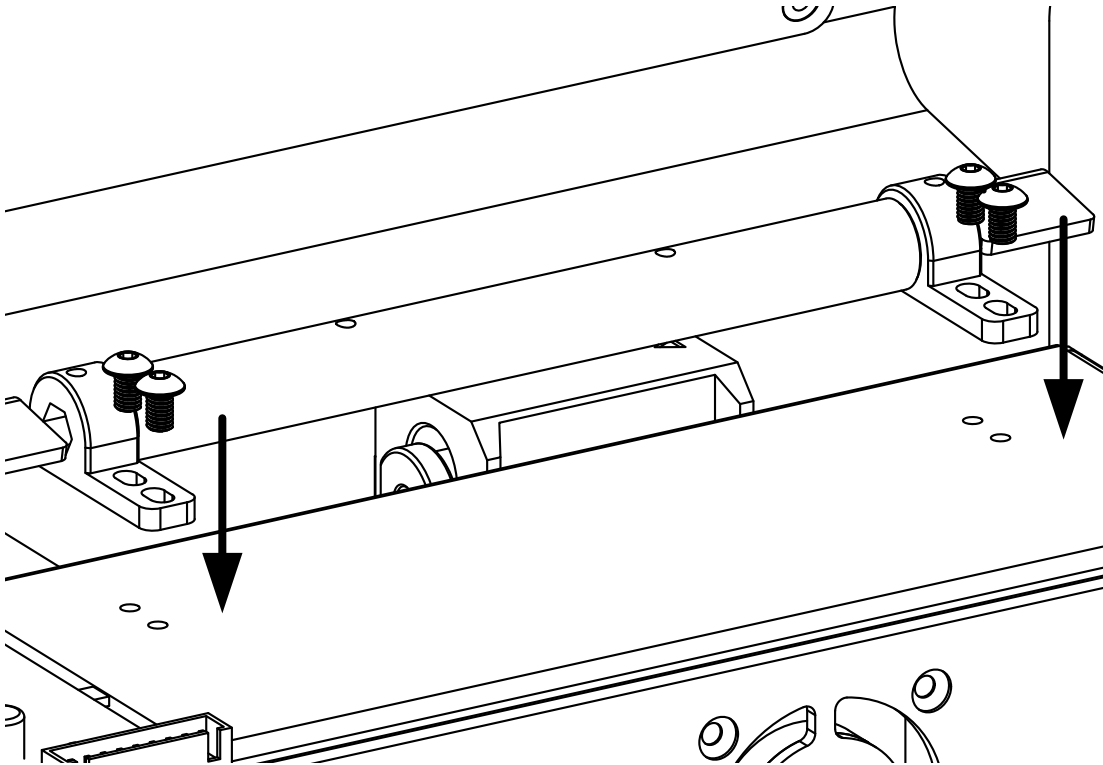

# 19

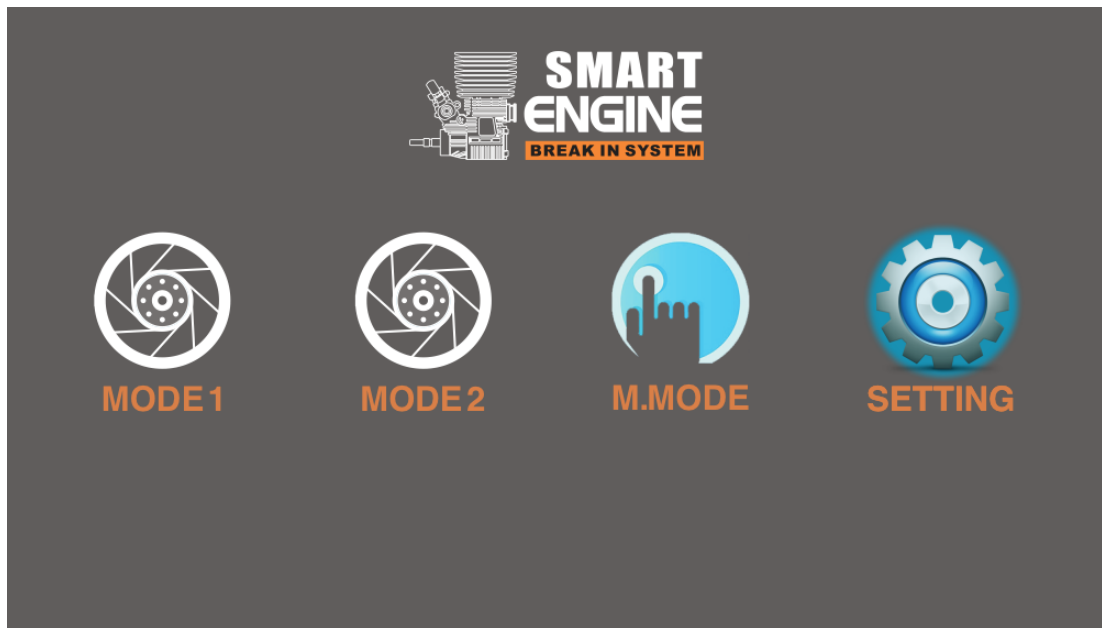

---

# 20

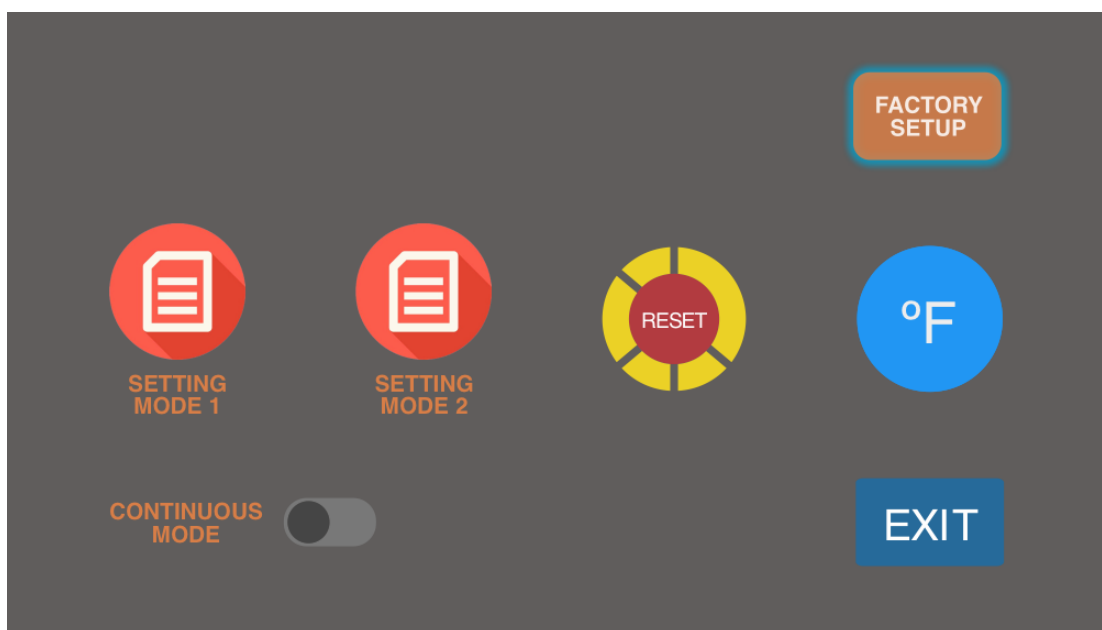

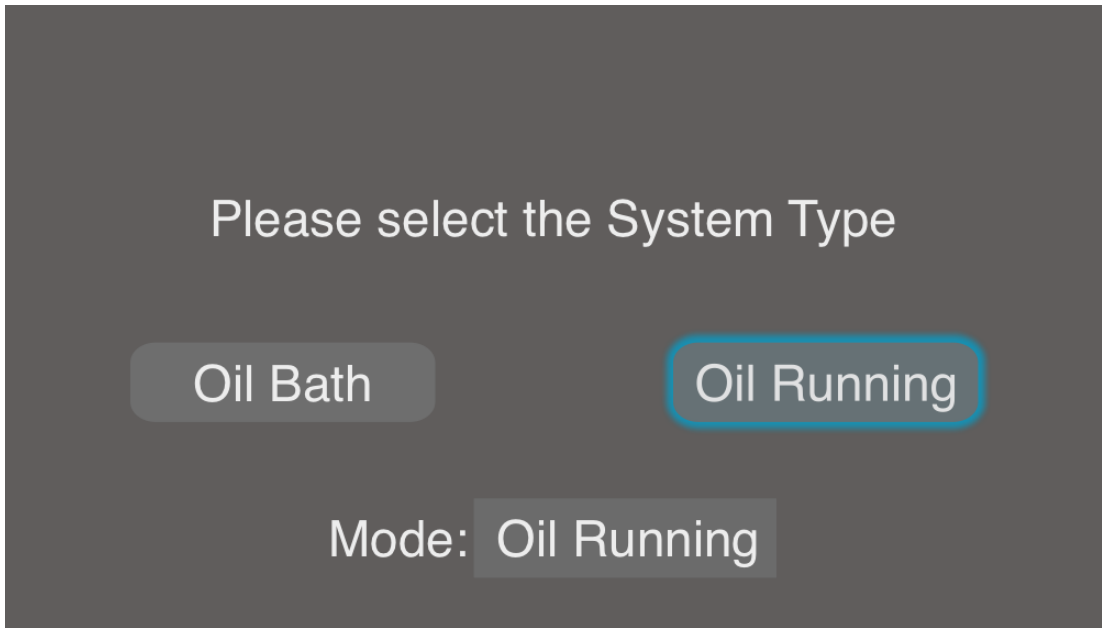

# How to open Oil Filter

---

1

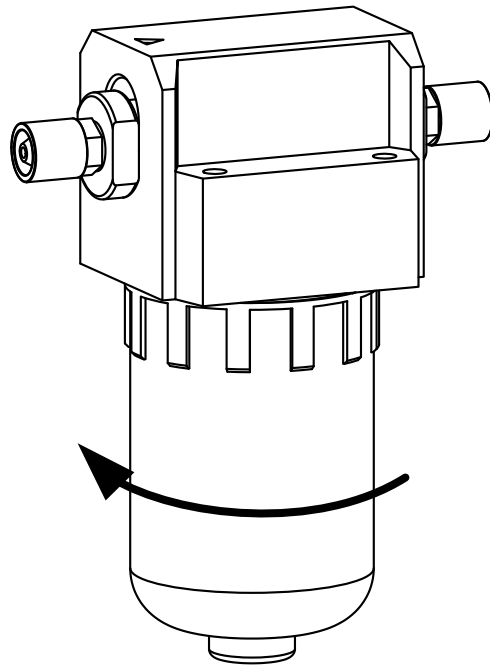

2

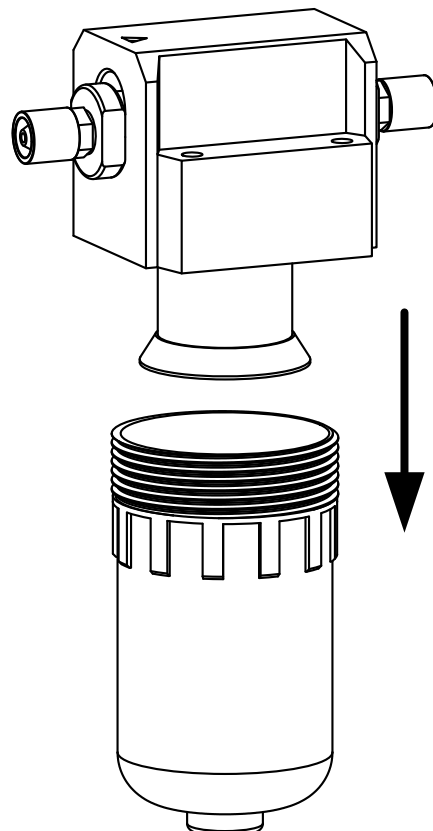





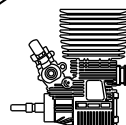

**SMART  
ENGINE**  
LAPPING SYSTEM

**SMART-WORKSHOP**  
Turning ideas into reality

Design and Manufacturer by SMART-Workshop

[www.smart-workshop.net](http://www.smart-workshop.net)

VER : 1.6